

JVC

SERVICE MANUAL

CD PORTABLE SYSTEM

RS-WP1WT

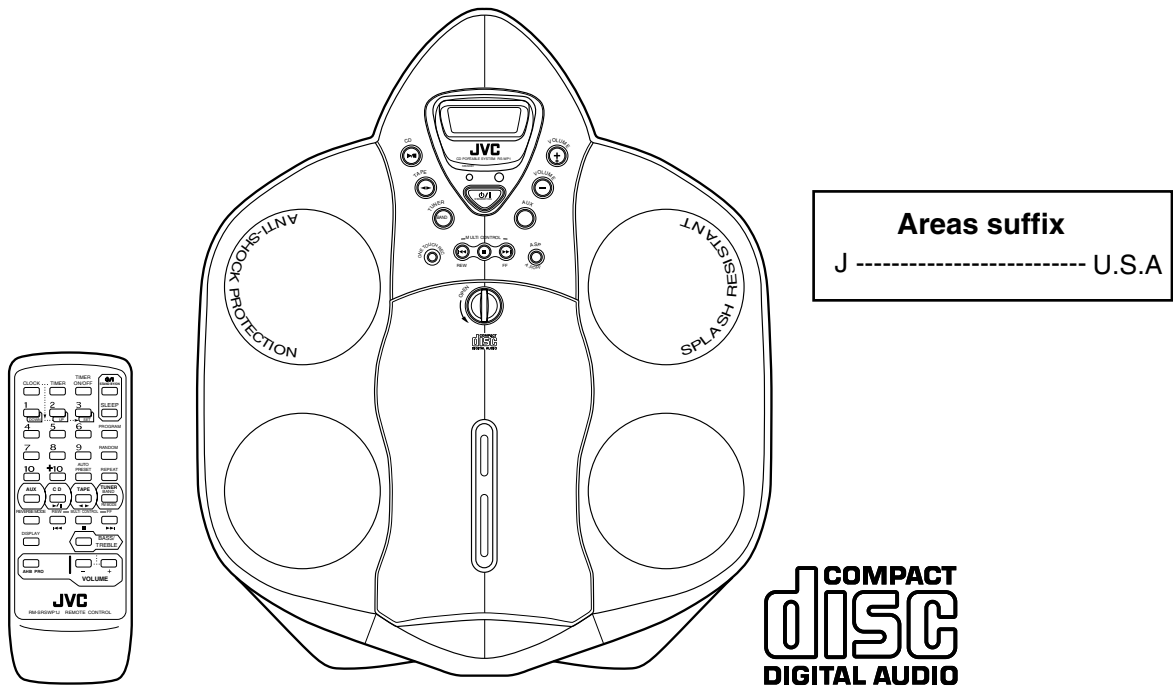

Areas suffix
 J ----- U.S.A

Contents

Safety Precautions	1-2	Flow of functional	
Important for laser products	1-3	operation unit Toc read	1-21
Preventing static electricity	1-4	Maintenance of laser pickup	1-22
Disassembly method	1-5	Replacement of laser picup	1-22
Adjustment method	1-17	Description of major ICs	1-23

Safety Precautions

1. This design of this product contains special hardware and many circuits and components specially for safety purposes. For continued protection, no changes should be made to the original design unless authorized in writing by the manufacturer. Replacement parts must be identical to those used in the original circuits. Services should be performed by qualified personnel only.
2. Alterations of the design or circuitry of the product should not be made. Any design alterations of the product should not be made. Any design alterations or additions will void the manufacturer's warranty and will further relieve the manufacture of responsibility for personal injury or property damage resulting therefrom.
3. Many electrical and mechanical parts in the products have special safety-related characteristics. These characteristics are often not evident from visual inspection nor can the protection afforded by them necessarily be obtained by using replacement components rated for higher voltage, wattage, etc. Replacement parts which have these special safety characteristics are identified in the Parts List of Service Manual. Electrical components having such features are identified by shading on the schematics and by (\triangle) on the Parts List in the Service Manual. The use of a substitute replacement which does not have the same safety characteristics as the recommended replacement parts shown in the Parts List of Service Manual may create shock, fire, or other hazards.
4. The leads in the products are routed and dressed with ties, clamps, tubings, barriers and the like to be separated from live parts, high temperature parts, moving parts and/or sharp edges for the prevention of electric shock and fire hazard. When service is required, the original lead routing and dress should be observed, and it should be confirmed that they have been returned to normal, after re-assembling.

5. Leakage current check (Electrical shock hazard testing)

After re-assembling the product, always perform an isolation check on the exposed metal parts of the product (antenna terminals, knobs, metal cabinet, screw heads, headphone jack, control shafts, etc.) to be sure the product is safe to operate without danger of electrical shock.

Do not use a line isolation transformer during this check.

- Plug the AC line cord directly into the AC outlet. Using a "Leakage Current Tester", measure the leakage current from each exposed metal parts of the cabinet, particularly any exposed metal part having a return path to the chassis, to a known good earth ground. Any leakage current must not exceed 0.5mA AC (r.m.s.).

- Alternate check method

Plug the AC line cord directly into the AC outlet. Use an AC voltmeter having, 1,000 ohms per volt or more sensitivity in the following manner. Connect a 1,500 Ω 10W resistor paralleled by a 0.15 μ F AC-type capacitor between an exposed metal part and a known good earth ground. Measure the AC voltage across the resistor with the AC voltmeter.

Move the resistor connection to each exposed metal part, particularly any exposed metal part having a return path to the chassis, and measure the AC voltage across the resistor. Now, reverse the plug in the AC outlet and repeat each measurement. Voltage measured any must not exceed 0.75 V AC (r.m.s.). This corresponds to 0.5 mA AC (r.m.s.).

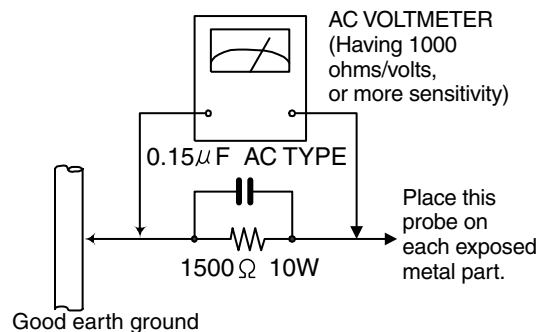

Warning

1. This equipment has been designed and manufactured to meet international safety standards.
2. It is the legal responsibility of the repairer to ensure that these safety standards are maintained.
3. Repairs must be made in accordance with the relevant safety standards.
4. It is essential that safety critical components are replaced by approved parts.
5. If mains voltage selector is provided, check setting for local voltage.

CAUTION

Burrs formed during molding may be left over on some parts of the chassis. Therefore, pay attention to such burrs in the case of preforming repair of this system.

In regard with component parts appearing on the silk-screen printed side (parts side) of the PWB diagrams, the parts that are printed over with black such as the resistor (■), diode (▣) and ICP (●) or identified by the " \triangle " mark nearby are critical for safety.

When replacing them, be sure to use the parts of the same type and rating as specified by the manufacturer. (Except the J and C version)

Important for Laser Products

1.CLASS 1 LASER PRODUCT

2.DANGER : Invisible laser radiation when open and interlock failed or defeated. Avoid direct exposure to beam.

3.CAUTION : There are no serviceable parts inside the Laser Unit. Do not disassemble the Laser Unit. Replace the complete Laser Unit if it malfunctions.

4.CAUTION : The compact disc player uses invisible laserradiation and is equipped with safety switches which prevent emission of radiation when the drawer is open and the safety interlocks have failed or are defeated. It is dangerous to defeat the safety switches.

5.CAUTION : If safety switches malfunction, the laser is able to function.

6.CAUTION : Use of controls, adjustments or performance of procedures other than those specified herein may result in hazardous radiation exposure.

CAUTION Please use enough caution not to see the beam directly or touch it in case of an adjustment or operation check.

WARNING : Osynlig laserstrålning är denna del är öppnad och spårren är urkopplad. Betrakta ej strålen.

VARO : Avattaessa ja suojalukitus ohitettaessa olet alltiina näkymättömälle lasersäteilylle. Älä katso säteeseen.

ADVARSEL : Usynlig laserstråling ved åbning , når sikkerhedsafbrydere er ude af funktion. Undgå udsættelse for stråling.

ADVARSEL : Usynlig laserstråling ved åbning,når sikkerhetsbryteren er avslott. unngå utsettelse for stråling.

REPRODUCTION AND POSITION OF LABELS

WARNING LABEL

CLASS 1
LASER PRODUCT

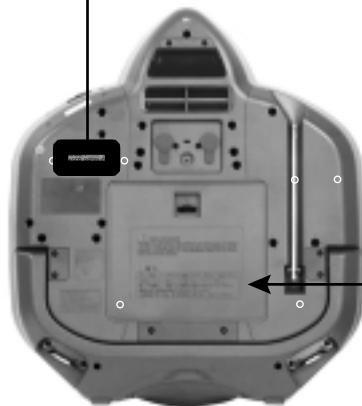

DANGER : Invisible laser radiation when open and interlock or defeated.
AVOID DIRECT EXPOSURE TO BEAM (e)

VARO : Avattaessa ja suojalukitus ohitettaessa olet alltiina näkymättömälle lasersäteilylle. Älä katso säteeseen. (d)

WARNING : Osynlig laserstrålning är denna del är öppnad och spårren är urkopplad. Betrakta ej strålen. (s)

ADVARSEL :Usynlig laserstråling ved åbning , når sikkerhedsafbrydere er ude af funktion. Undgå udsættelse for stråling. (f)

Preventing static electricity

1. Grounding to prevent damage by static electricity

Electrostatic discharge (ESD), which occurs when static electricity stored in the body, fabric, etc. is discharged, can destroy the laser diode in the traverse unit (optical pickup). Take care to prevent this when performing repairs.

2. About the earth processing for the destruction prevention by static electricity

Static electricity in the work area can destroy the optical pickup (laser diode) in devices such as CD players.

Be careful to use proper grounding in the area where repairs are being performed.

2-1 Ground the workbench

Ground the workbench by laying conductive material (such as a conductive sheet) or an iron plate over it before placing the traverse unit (optical pickup) on it.

2-2 Ground yourself

Use an anti-static wrist strap to release any static electricity built up in your body.

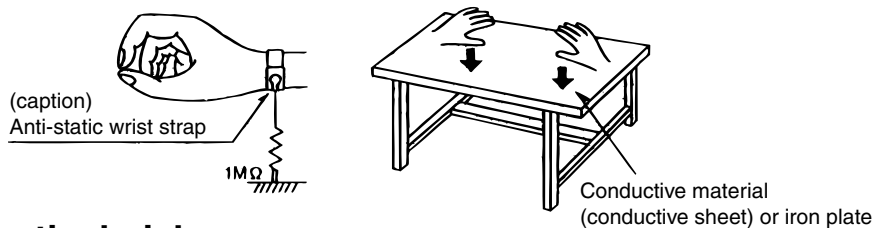

3. Handling the optical pickup

1. In order to maintain quality during transport and before installation, both sides of the laser diode on the replacement optical pickup are shorted. After replacement, return the shorted parts to their original condition. (Refer to the text.)
2. Do not use a tester to check the condition of the laser diode in the optical pickup. The tester's internal power source can easily destroy the laser diode.

4. Handling the traverse unit (optical pickup)

1. Do not subject the traverse unit (optical pickup) to strong shocks, as it is a sensitive, complex unit.
2. Cut off the shorted part of the flexible cable using nippers, etc. after replacing the optical pickup. For specific details, refer to the replacement procedure in the text. Remove the anti-static pin when replacing the traverse unit. Be careful not to take too long a time when attaching it to the connector.
3. Handle the flexible cable carefully as it may break when subjected to strong force.
4. It is not possible to adjust the semi-fixed resistor that adjusts the laser power. Do not turn it

CAUTION: Prior to disconnecting the flexible wire extending from the pickup, solder it to the short circuit land to prevent damage to the pickup.

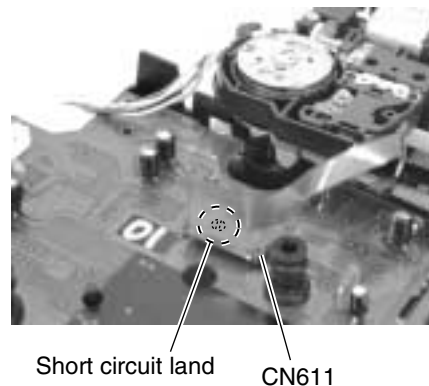

Disassembly method

■ Removing the front panel assembly / rear panel assembly (See Fig.1)

1. Remove the nine screws **A** attaching the rear panel assembly on the back of the body.
2. Pull out the front panel assembly and the rear panel assembly. Disconnect the speaker terminal on the front side and connector CN112 on the connection board on the rear side at the same time.

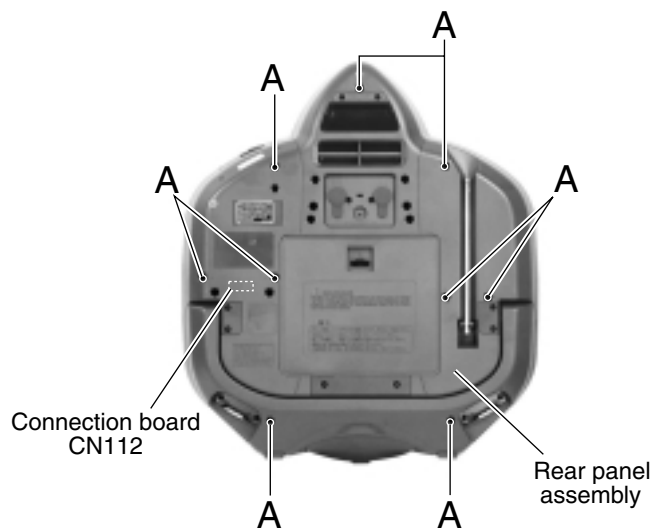

Fig.1

■ Removing the CD mechanism assembly section (See Fig.2)

- Prior to performing the following procedures, remove the rear panel assembly.
1. Disconnect the card wire from connector CN614 and the wire from CN624 on the CD mechanism assembly respectively.
 2. Remove the three screws **B** attaching the CD mechanism assembly section.

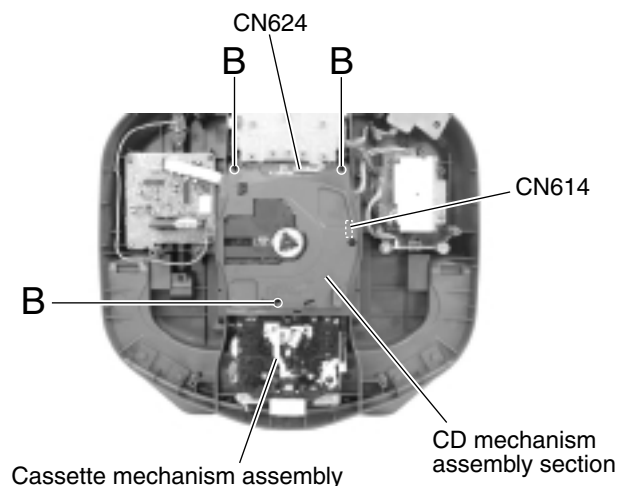

Fig.2

■ Removing the cassette mechanism assembly (See Fig.3)

- Prior to performing the following procedures, remove the rear panel assembly and the CD mechanism assembly section.
1. Disconnect the card wire from connector CN33, CN34 on the cassette mechanism assembly.
 2. Remove the four screws **C** and the cassette mechanism assembly with the wire cover.

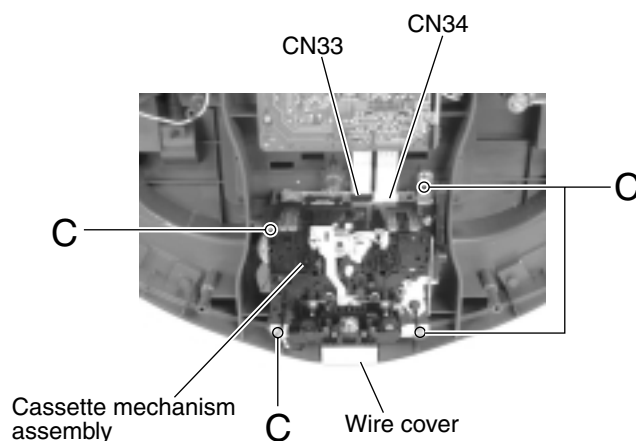

Fig.3

■ **Removing the function switch board**
(See Fig.4)

- Prior to performing the following procedures, remove the rear panel assembly.
1. Disconnect the card wire from connector CN921 on the function switch board.
 2. Remove the two screws **D** and move the function switch board in the direction of the arrow to disengage the two joints **a**.

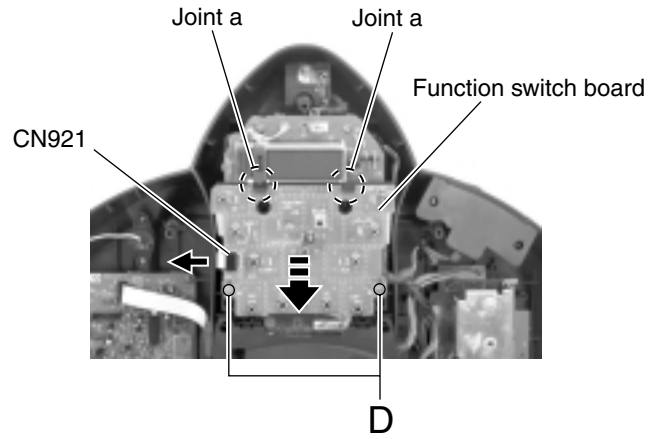

Fig.4

■ **Removing the LCD spare board / LED board**
(See Fig.5 and 6)

- Prior to performing the following procedures, remove the rear panel assembly.
1. Remove the LCD spare board while pulling each joint hook **b** outward.
 2. Pull out the LED board.
 If necessary, unsolder FW925 soldering the wire on the LED board.

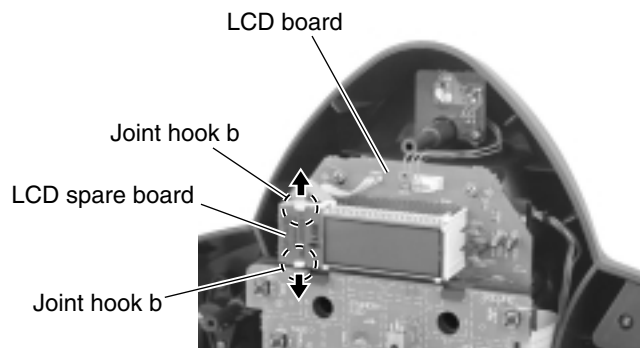

Fig.5

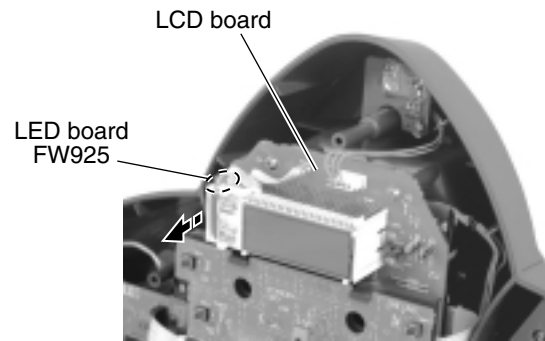

Fig.6

■ Removing the LCD board (See Fig.7 and 8)

- Prior to performing the following procedures, remove the rear panel assembly and the function switch board.

1. Remove the four screws **E** attaching the bracket.
2. Disconnect the card wire from connector CN421, CN422 and the wire from CN913 on the LCD board respectively.
3. Disconnect the wire from connector CN624 on the CD mechanism assembly.
4. Remove the two screws **F** attaching the LCD board
(The LCD spare board and the LED board are still attached to the LCD board).

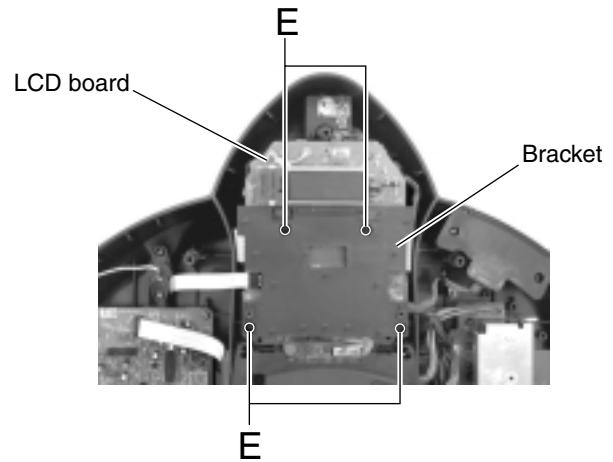

Fig.7

■ Removing the headphone jack board (See Fig.9 and 10)

- Prior to performing the following procedures, remove the rear panel assembly.

1. Remove the two screws **G** attaching the headphone jack board bracket.
2. Pull out the headphone jack board bracket and the headphone cover at the same time.
3. Remove the two screws **H** attaching the headphone jack board.
4. Disconnect the wire from connector CN711 on the headphone jack board.

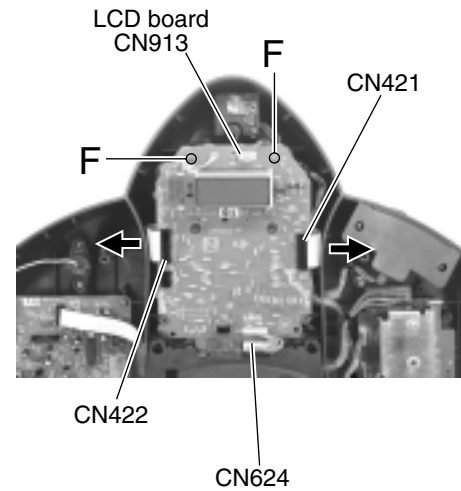

Fig.8

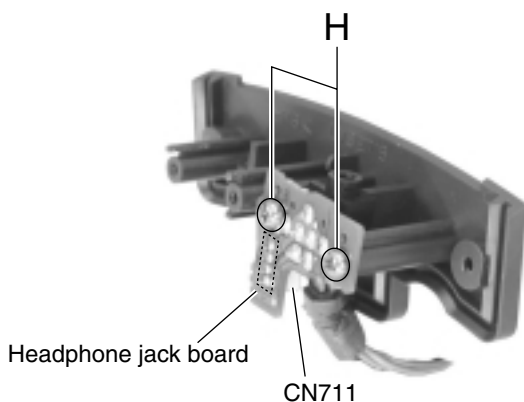

Fig.10

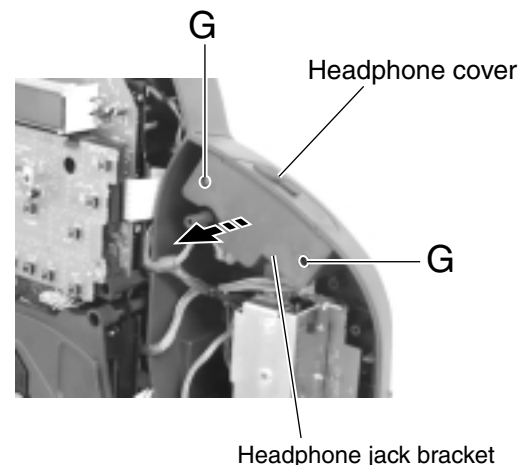

Fig.9

■ Removing the main board / sub (1) board / sub (2) board (See Fig.11 to 13)

- Prior to performing the following procedures, remove the rear panel assembly, the CD mechanism assembly section and the LCD board.

1. Remove the two screws **J** attaching the main board on the back of the rear panel assembly.
2. Disconnect the card wire from connector CN43 and CN44 on the main board on the inside of the rear panel assembly.
3. Disconnect the wire from connector CN101 and CN103 on the power board.
4. Disconnect the wire from connector CN401 on the battery board.
5. Remove the six screws **K** attaching the main board. Disconnect the card wire from connector CN91 on the reverse side of the main board.
6. Remove the screw **L** and disconnect the sub (1) board from connector CN341 on the main board.
7. Disconnect the sub (2) board from connector CN371 on the main board.

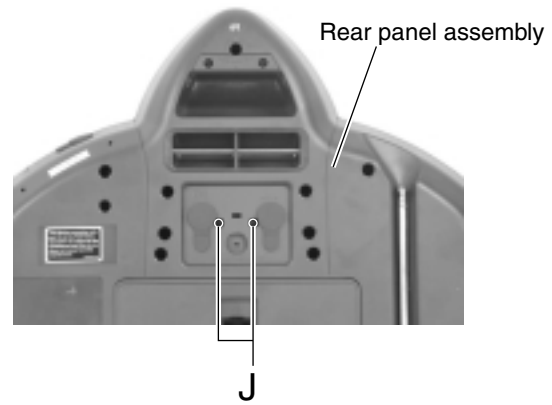

Fig.11

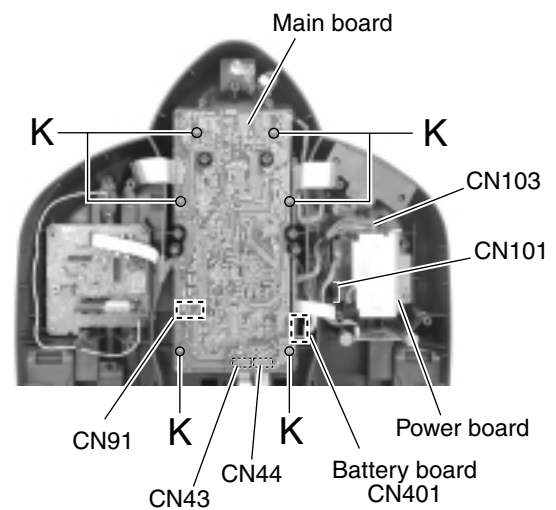

Fig.12

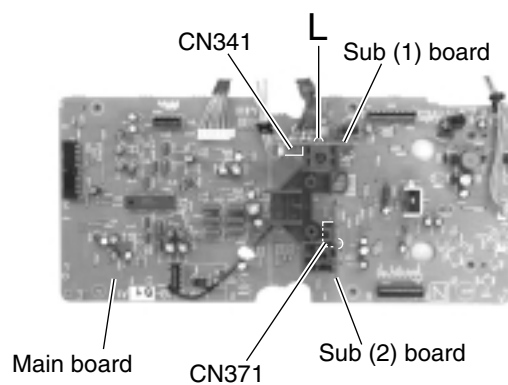

Fig.13

■ Removing the remocon board (See Fig.14)

- Prior to performing the following procedure, remove the rear panel assembly.
1. Remove the screw **M** attaching the remocon board and disconnect the wire from connector CN913 on the LCD board.

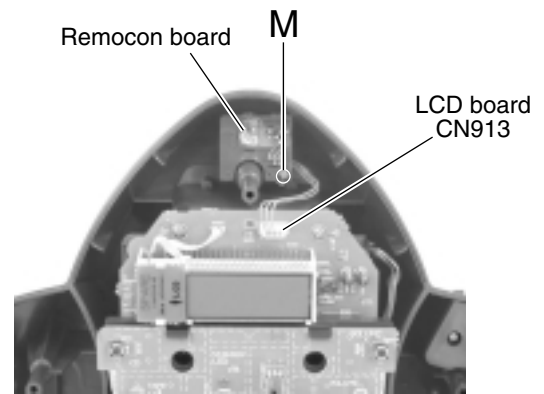

Fig.14

■ Removing the tuner board (See Fig.15)

- Prior to performing the following procedures, remove the rear panel assembly.
1. Disconnect the card wire from connector CN1 and the antenna wire from TP1 on the tuner board respectively.
 2. Remove the four screws **N** attaching the tuner board.

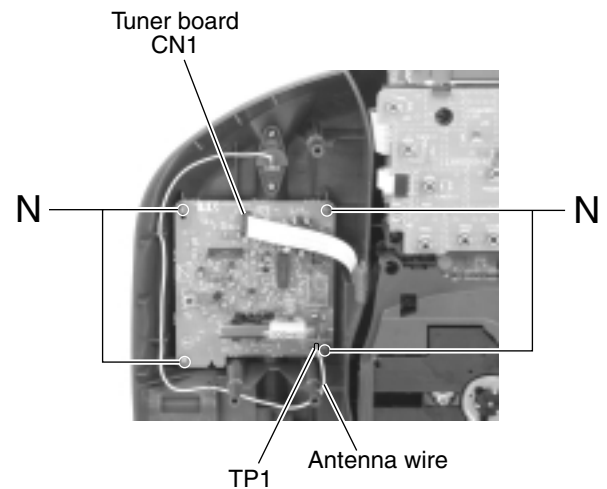

Fig.15

■ **Removing the power board**
(See Fig.16 to 18)

• Prior to performing the following procedures, remove the rear panel assembly.

1. Disconnect the wire from connector CN101, CN102 and CN103 on the power board.
2. Remove the four screws **O** attaching the power board.
3. Remove the three screws **O'** attaching the heat sink.
4. Disengage the two joints **c** and remove the heat sink from the power board.

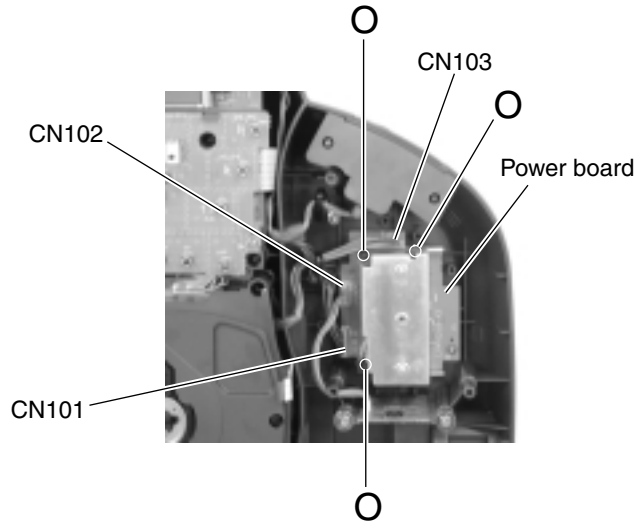

Fig.16

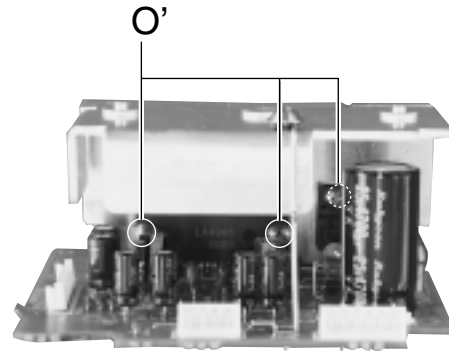

Fig.17

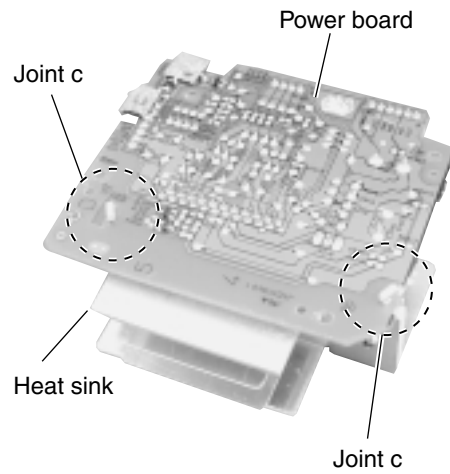

Fig.18

■ Removing the connection board (See Fig.19)

- Prior to performing the following procedures, remove the rear panel assembly.
1. Disconnect the wire from connector CN102 on the power board.
 2. Remove the two screws **P** and pull out the connection board.

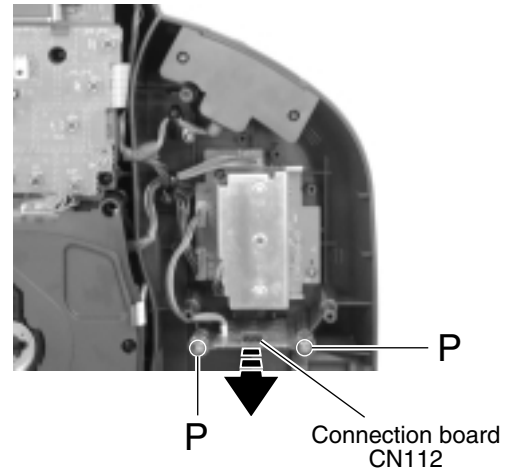

Fig.19

■ Removing the battery board (1) / battery board (2) (See Fig.20 and 21)

- Prior to performing the following procedures, remove the rear panel assembly.
1. Remove the battery cover on the back of the rear panel assembly.
 2. Remove the two screws **Q** retaining the battery board (1).
 3. Pull out the battery board (1) and disconnect the wire from inner connector CN401.
 4. Remove the two screws **R** and pull out the battery board (2).

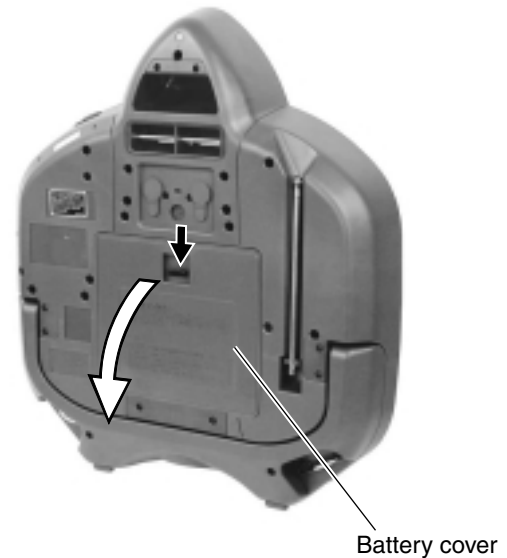

Fig.20

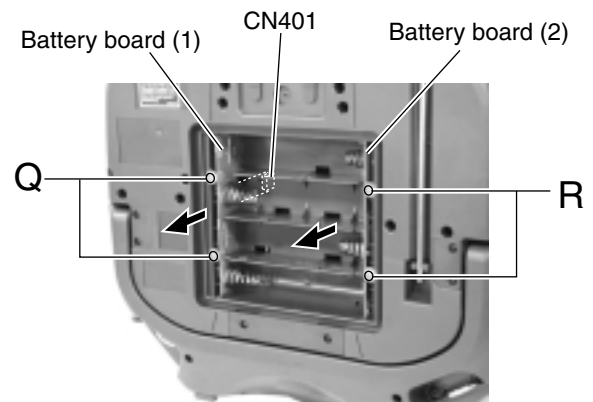

Fig.21

<CD mechanism assembly section>

- Prior to performing the following procedures, remove the rear panel assembly and the CD mechanism assembly section.

■ Removing the CD mechanism assembly (See Fig.22 to 26)

CAUTION: Prior to disconnecting the flexible wire extending from the pickup, solder it to the short circuit land to prevent damage to the pickup.

1. Release the three joint hooks **d** retaining the CD mechanism cover.
2. Disconnect the wire from connector CN612 on the CD servo board.
3. Remove the CD mechanism assembly from the three dampers.
4. Solder the flexible wire connected to connector CN611 on the CD servo board to the short circuit land under the flexible wire.
After soldering, disconnect the pickup wire from connector CN611.

CAUTION: When reassembling, connect the pickup wire extending from the pickup to connector CN611 on the CD servo board. Then unsolder the wire soldered to the short circuit land.

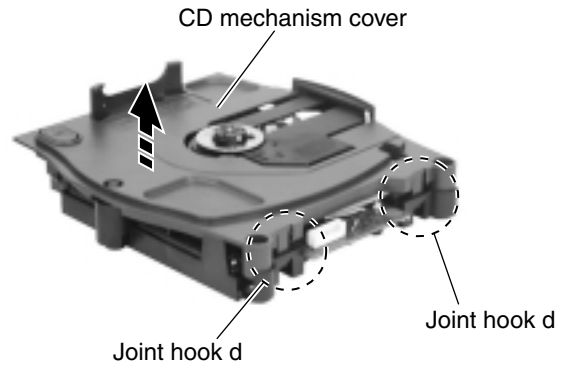

Fig.22

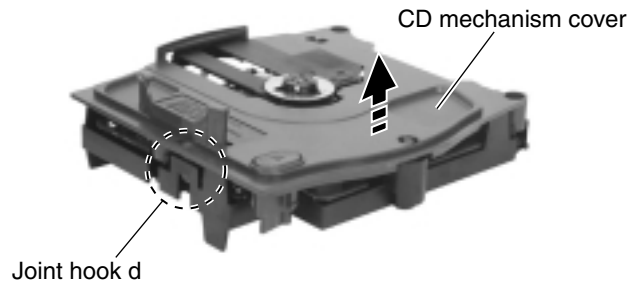

Fig.23

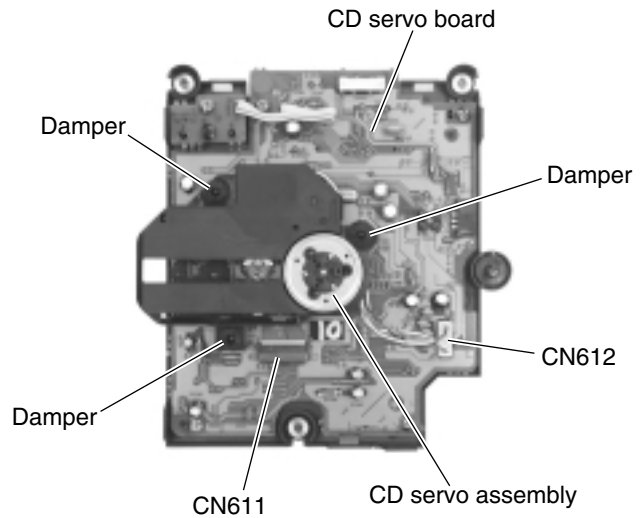

Fig.24

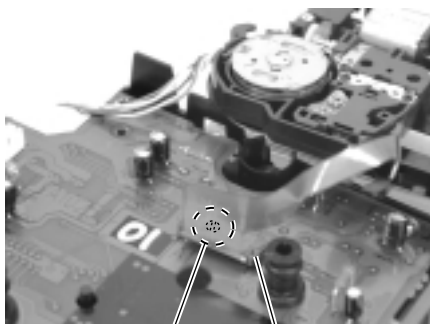

Fig.26

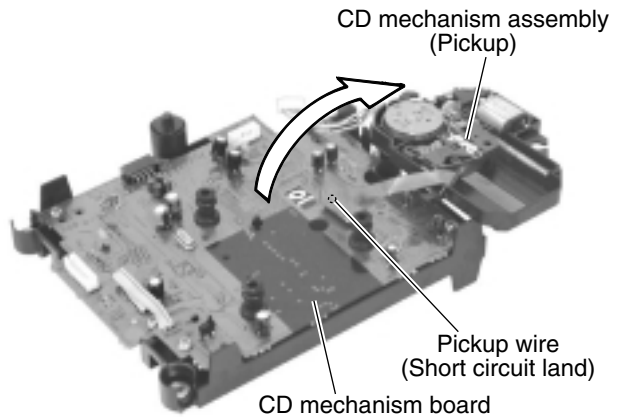

Fig.25

■ Removing the CD servo board

(See Fig.27)

- Prior to performing the following procedure, remove the CD servo assembly.
1. Remove the four screws **S** retaining the CD servo board.
 2. Unsolder FW616 where the wire extending from the OPEN / CLOSE switch board is soldered.

■ Removing the OPEN / CLOSE switch board (See Fig.27)

- Prior to performing the following procedure, remove the CD mechanism cover.
1. Remove the screw **T** retaining the OPEN / CLOSE switch board.
 2. Unsolder FW626 where the wire extending from the CD mechanism board is soldered.

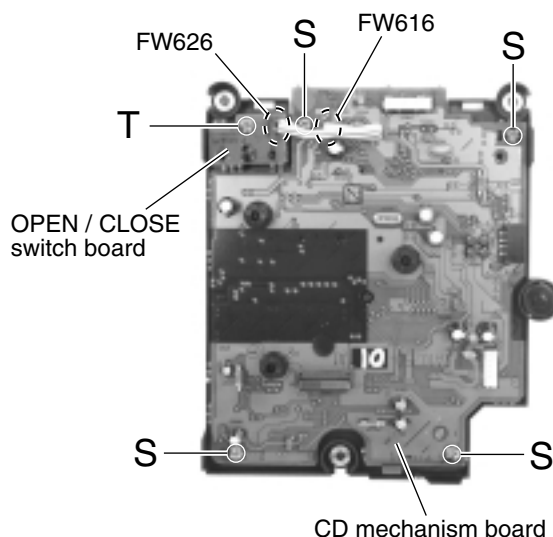

Fig.27

<Front assembly>

■ Removing the speaker assembly (R) and (L) (See Fig.28)

- Prior to performing the following procedure, remove the front assembly.
1. Remove the four screws **U** attaching the speaker assembly (R).
 2. Remove the four screws **V** attaching the speaker assembly (L).
 3. Remove the screw **W** attaching the speaker terminal. If necessary, disconnect the wire from each speaker terminal.

■ Removing the sub speaker assembly (R) and (L) (See Fig.28)

- Prior to performing the following procedure, remove the front assembly.
1. Remove the four screws **X** attaching the sub speaker assembly (R).
 2. Remove the four screws **Y** attaching the sub speaker assembly (L). If necessary, disconnect the wire from each speaker terminal.

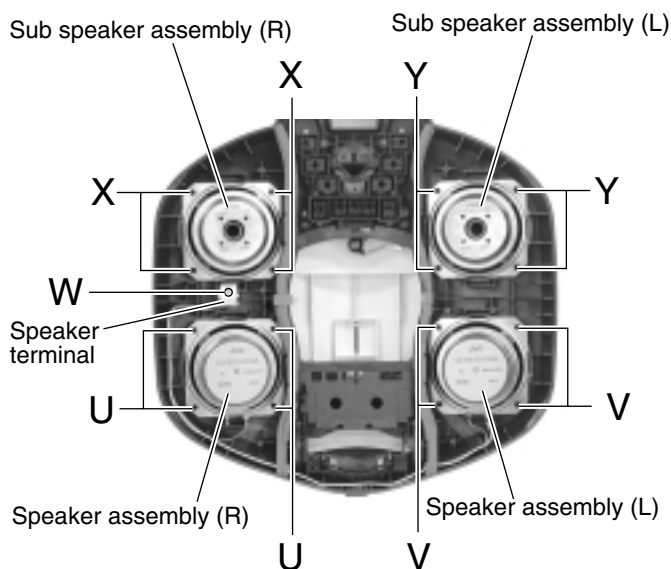
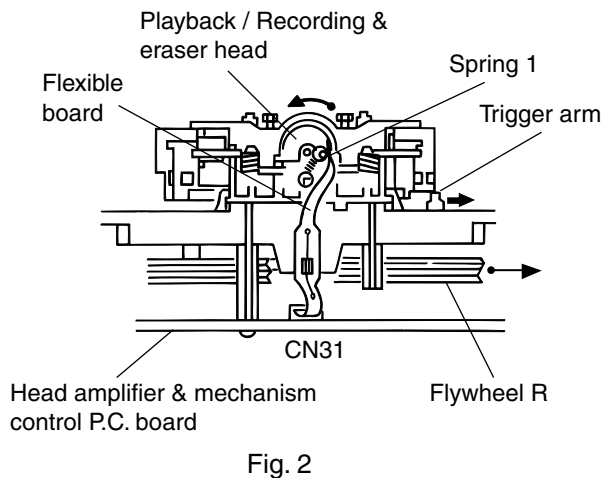
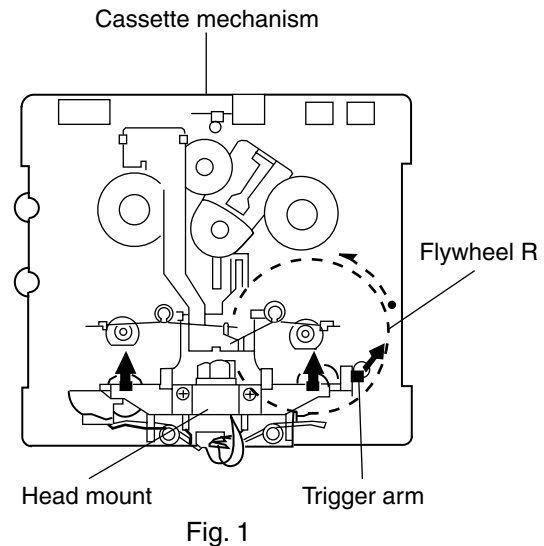

Fig.28

<Cassette mechanism section>

■ Removing the playback / recording & eraser head (See Fig. 1 to 3)

1. While shifting the trigger arms seen on the right side of the head mount in the arrow direction, turn the flywheel R in counterclockwise direction until the head mount has gone out with a click (See Fig. 1).
2. When the flywheel R is rotated in counterclockwise direction, the playback / recording & eraser head will be turned in counterclockwise direction from the position in Fig. 2 to that in Fig. 3.
3. At this position, disconnect the flexible P.C. board (outgoing from the playback / recording & eraser head) from the connector CN31 on the head amplifier & mechanism control P.C. board.
4. Remove the flexible P.C. board from the chassis base.
5. Remove the spring 1 from behind the playback / recording & eraser head.
6. Loosen the reversing azimuth screw retaining the playback / recording & eraser head.
7. Take out the playback / recording & eraser head from the front of the head mount.
8. The playback / recording & eraser head should also be removed similarly according to steps 1 to 7 above.



■ Reassembling the playback / recording & eraser head (See Fig.3)

1. Reassemble the playback head from the front of the head mount to the position as shown in Fig. 3.
2. Fix the reversing azimuth screw.
3. Set the spring 1 from behind the playback / recording & eraser head.
4. Attach the flexible P.C. board to the chassis base, as shown in Fig. 3.
5. The playback / recording & eraser head should also be reassembled similarly to step 1 to 4 above.

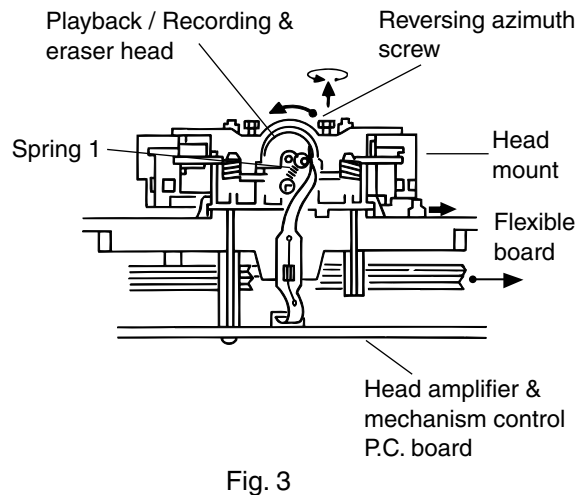

■ Removing the head amplifier & mechanism control board (See Fig. 4)

1. Remove the cassette mechanism assembly.
2. Disconnect the flexible wire from connector CN31 to the flexible board.
3. After turning over the cassette mechanism assembly, remove the three screws **A** retaining the head amplifier & mechanism control board.
4. Disconnect the connector CN32 on the board including the connector CN 1 on the reel pulse P.C. board.
5. When necessary, remove the 4 pin parallel wire soldered to the main motor.

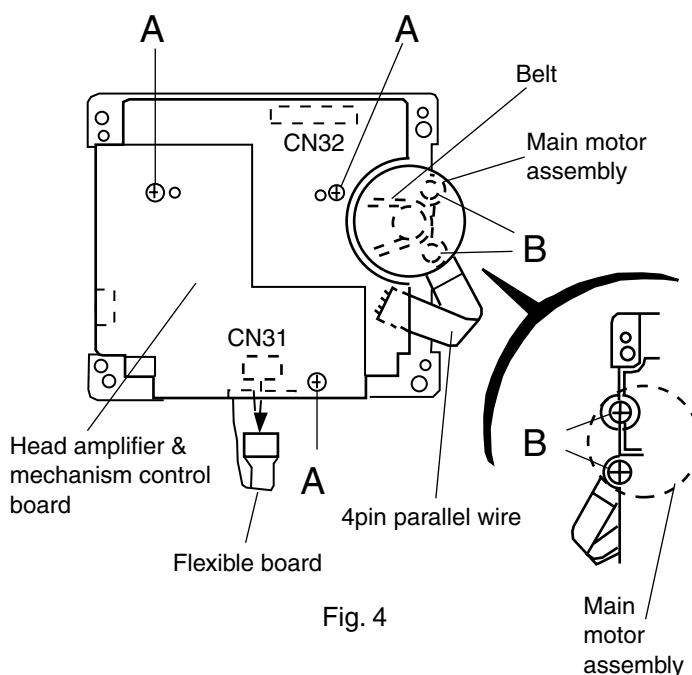

■ Removing the main motor assembly

1. Remove the two screws **B** retaining the main motor assembly (See Fig. 4 and 4a).
2. While raising the main motor, remove the capstan belt from the motor pulley (See Fig. 4a).

CAUTION: Be sure to handle the capstan belt so carefully that this belt will not be stained by grease and other foreign matter. Moreover, this belt should be hanged while referring to the capstan belt hanging method in Fig. 5 and 6.

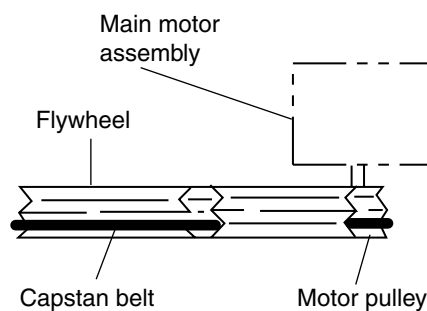
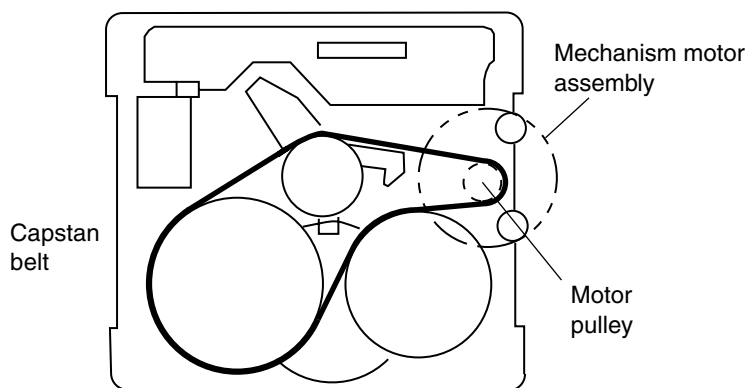
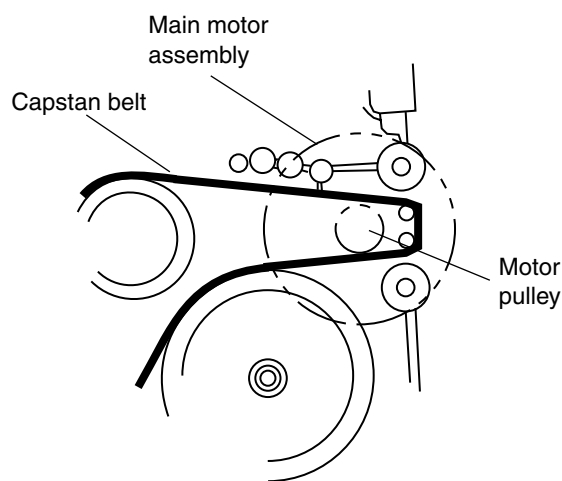

■ **Removing the flywheel (See Fig. 7 and 8)**

1. Remove the head amplifier & mechanism control P.C. board.
2. Remove the main motor assembly.
3. After turning over the cassette mechanism, remove the two slit washers **1** and fixing the capstan shafts R and L, and pull out the flywheel R and L respectively from behind the cassette mechanism.

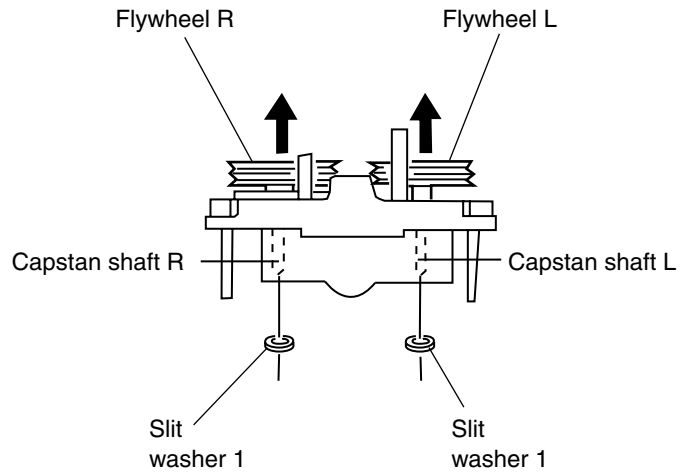
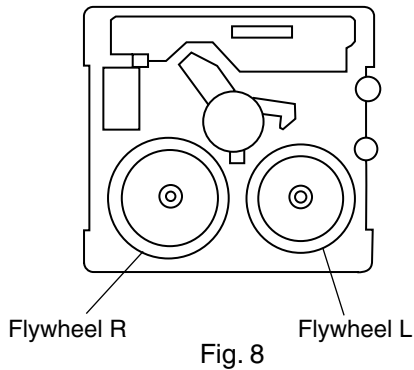

Fig. 7

■ **Removing the mecha braket reel pulse P.C. board and solenoid (See Fig. 9 and 10)**

1. Remove the screw C attaching the mecha braket assembly on the cassette assembly.
2. Remove the screw D attaching the reel pulse board.
3. Remove the five pawls **a** to **e** reattaining the reel pulse board.
4. From the surface of the reel pulse board parts, remove the two pawls **f** and **g** retaining the solenoid.

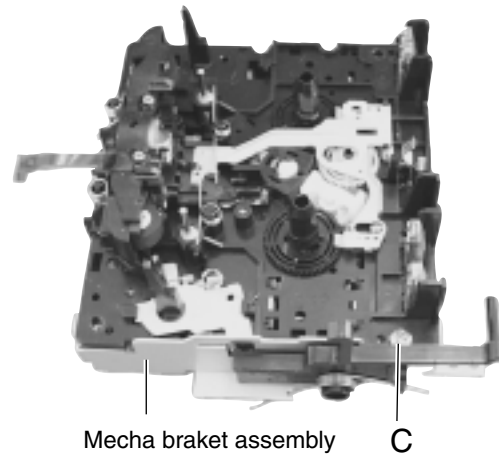

Fig. 9

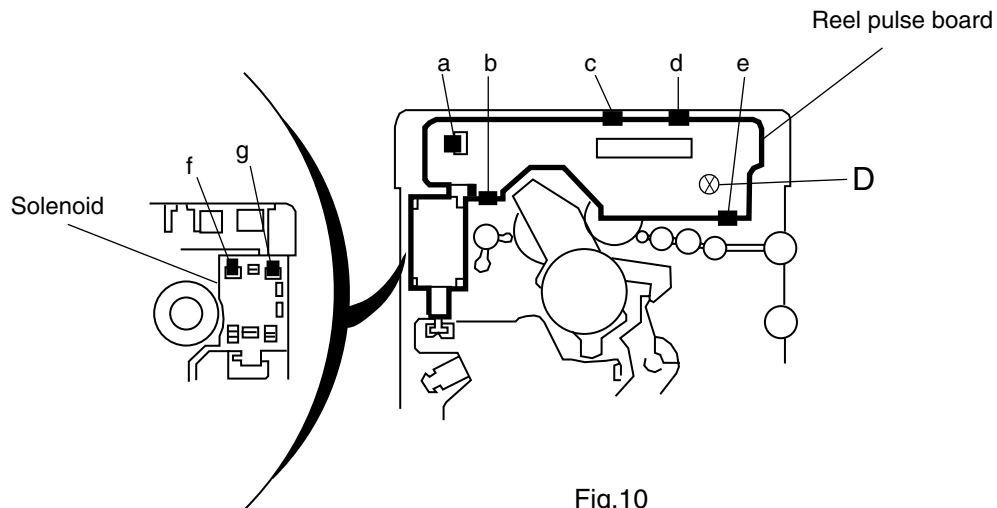

Fig.10

Adjustment method

■ Measuring devices necessary for adjustment

1. Low-frequency oscillator
It must have the ability to output 600ohm from 0 dBs at an oscillation frequency of 20 Hz-50 Hz.
2. Attenuator impedance: 600ohm
3. Electronic voltmeter
4. Distortion meter
5. Frequency counter
6. Wow and flutter meter
7. Test tapes
VT-712: tape speed and rotational distortion (3 kHz)
VT-724: standard level (1 kHz)
VT-703: head angle adjustment (10 kHz),
or use VT-73
VT-739: reproduction of frequency characteristics
(1 kHz, 63 Hz, 10 kHz)
8. Blank tape
Type I : AC-225 (TDK-AD)
Type II : AC-514 (TDK-SA)
9. Torque gauge: Tension gauge for playback,
fast-forward and rewind.
FWD (TW211A), REW (TW212A)
and FF/REW (TW2231A)

■ Specifications for measurement

- Power supply voltage AC 230 V (50 Hz)
Standard output Speaker: 0.775V/4ohm
Headphone: 0.245V/32ohm
Standard frequency and input level
..... 1 kHz: AUX: -8 dBs
Input level for reproduction of recording characteristics
..... AUX: -28 dBs
Measuring output terminal Speaker: CN112
Load resistance 4ohm

■ Radio input signal

- AM frequency 400 Hz
Degree of modulation in AM band 30%
FM frequency 400 Hz
Frequency deviation in FM band 22.5 kHz

■ Tuner section

- Voltage input to the tuner +B: DC 5.7 V
VT: DC 12 V
Standard measuring output 26.1 mV (0.28 V)/3ohm
Input locations AM: standard loop antenna
FM: TP1 (hot) and TP2 (GND)

■ Standard settings for measuring volume

- Sound OFF
Effective hyper bass OFF
Volume adjustment VOL. 23

Precautions for measuring

1. Input 30 pF and 33 kohm to the IF sweeper output and 0.082 μ F and 100 kohm to the sweeper input, respectively.
2. Lower the output level of the IF sweeper as much as possible in the adjustable range.
3. The IF sweeper needs no adjustment as it is a fixed component.
4. It is not necessary to perform any kind of adjustment on the MPX, as a ceramic oscillator is used for measuring.
5. FM tracking adjustment is not necessary as a fixed coil is used.
6. The grounding circuit is separate from the input and output. Therefore, be sure to connect to ground carefully when measuring both the input and output voltages simultaneously using 2 channels of the electronic voltmeter.
7. The speaker's minus terminal cannot be connected to ground when using a BTL format amplifier. Therefore, do not connect any type of ground wire to this terminal. The OTL format is used with this system.
8. Use a large wire to connect to the dummy impedance generator when measuring the output.
9. Be sure to use a band pass filter (DV-12) when using mixed tape.

Location of parts to be adjusted

■ **Cassette handling mechanism**

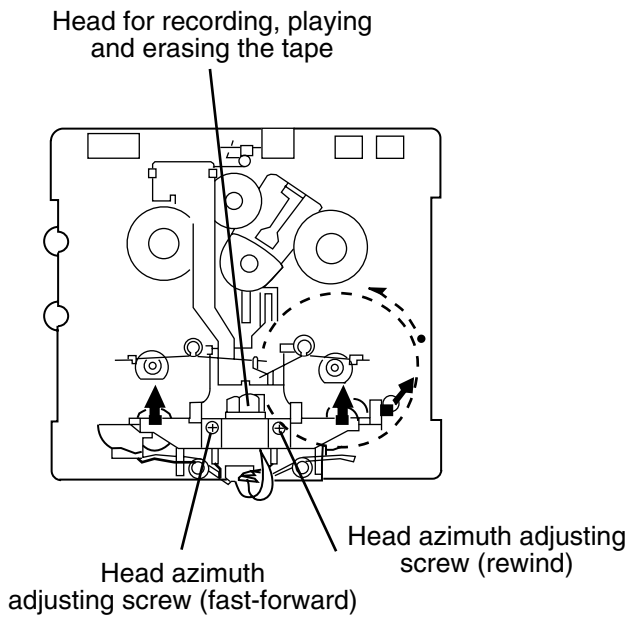

■ **Cassette handling mechanism (reverse side)**

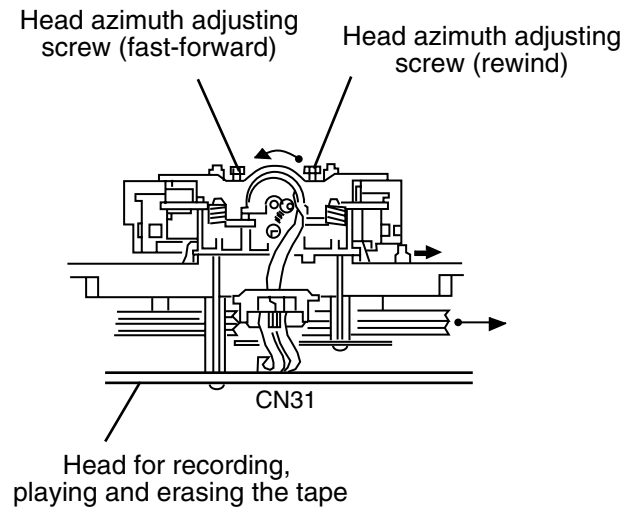

■ **Location of parts to be adjusted**

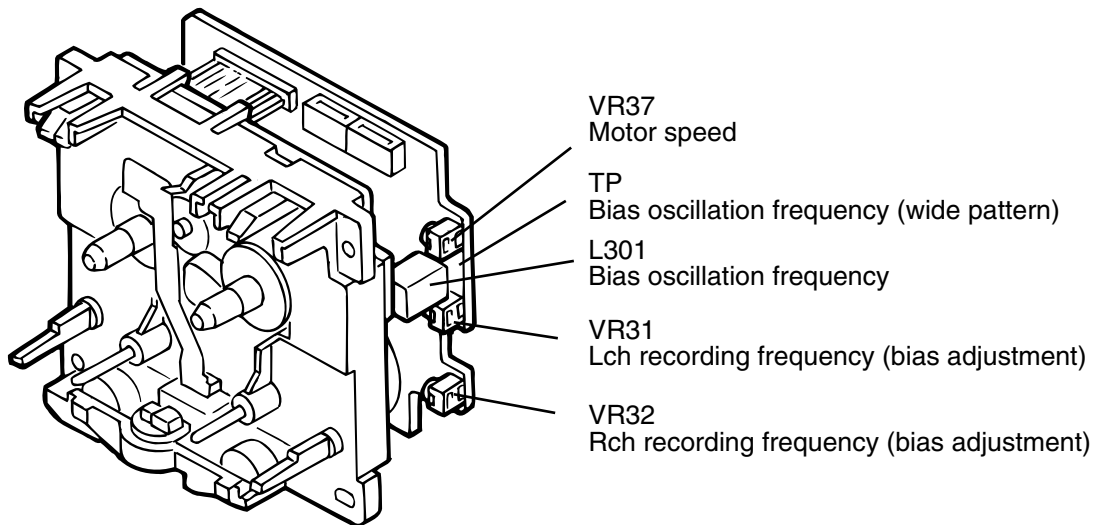

■ Adjustment of cassette handling mechanism

Items	Condition	Method for adjustment and confirmation	Standard value	Parts to be adjusted
Confirmation of head angle	Test tape: VT-703 (10 kHz) Measuring output terminal: Speaker terminal, speaker (R) (Load resistance: 4ohm), headphone terminal	(1) Play back the VT-703 test tape. (2) Adjust the head azimuth screws so that the tape playback mechanism records the maximum output level in both the fast-forward and rewind direction. (3) In all cases, both the fast-forward and rewind direction should be adjusted using head azimuth screws.	Maximum output	Adjust the head azimuth screws when changing the head.
Confirmation of tape speed	Test tape: VT-712 (3 kHz) Measuring output terminal: Headphone terminal	Adjust VR37 so that the frequency counter records 3,015 Hz \pm 15 Hz when playing back the end of the VT-712 test tape (3 kHz) in the fast-forward direction.	Tape speed of cassette deck: 3,015 Hz \pm 15 Hz	VR37

■ Items to be confirmed and standard values

Items	Condition	Method for adjustment and confirmation	Standard value	Parts to be adjusted
Difference in speed between fast-forward and rewind	Test tape: VT-712 (3 kHz) Measuring output terminal: Speaker terminal, speaker (R) (Load resistance: 4), headphone terminal	The difference between fast-forward and rewind should be less than 60 Hz on the frequency counter when playing back the beginning of the VT-712 test tape (3 kHz) in both directions.	Less than 60 Hz	Should be confirmed when changing the motor.
Wow and flutter	Test tape: VT-712 (3 kHz) Measuring output terminal: Headphone terminal	Wow and flutter should be recorded at less than 0.25% (WRMS) when playing back the VT-712 test tape (3 kHz) in the fast-forward direction.	Less than 0.25% (WRMS)	

■ Electronic performance

Items	Condition	Method for adjustment and confirmation	Standard value	Parts to be adjusted
Confirmation of output	Measuring output terminal: CN34-5 or 7-terminal preamp base Test tape: VT-724	Confirm that the output from the CN34-5 or 7-terminal preamp base connector is -25 dBs \pm 3 dB when playing back the VT-724 test tape. Reference value: The output from the headphone terminal is -7 dB \pm 4 dB.	Output of CN34-5 terminal: -25 dBs \pm 3 dB Difference between Lch and Rch: within 3 dB	
Confirmation of reproduction of frequency characteristics	Measuring output terminal: Headphone terminal Test tape: VT-739	Confirm that the 10 kHz reproduction level is -1 dB \pm 5 dB compared to the 1 kHz reproduction level when playing back the VT-739 test tape.	Difference between 10 kHz and 1 kHz should be -1 dB \pm 5 dB.	
Recording bias frequency	Fast-forward or rewind direction: Test tape: TYPE II (AC-514) Measuring terminal: Bias TP on the base	Switch the bias (beat cut switch) between 1 and 2 to confirm that the frequency changes. Load the test tape (AC-514 for TYPE II) into the mechanism and preset it to the record-pause mode. Confirm that the bias TP frequency on the base is 100 kHz \pm 6kHz.	100 kHz \pm 6 kHz	

■ Standard values for confirmation of electronic performance

Items	Condition	Method for adjustment and confirmation	Standard value	Parts to be adjusted
Erasing current (standard and reference value)	Fast-forward and rewind direction: <ul style="list-style-type: none"> • Recording mode • AC-514 for TYPE II, AC-225 for TYPE I Measuring terminal: Both erase head terminals	Load the test tape (AC-514 for TYPE II, AC-225 for TYPE I) into the tape playback mechanism and preset it to the record-pause mode. After setting it to the recording mode, send 1 M in series to the erase head and measure the erasing current from both erase head terminals.	TYPE II: 110 mA TYPE I: 75 mA	
Adjustment of reproduction of frequency characteristics	Standard frequencies: 1 kHz and 10 kHz (REF: -20 dB) Test tape: TYPE II: AC-514 Measuring input terminal: OSC IN	Load the test tape (AC-514 for TYPE II, AC-225 for TYPE I) into the tape playback mechanism and preset it to the record-pause mode. Input the standard value of -20 dB and the standard frequencies of 1 kHz and 10 kHz repeatedly to the microphone input from the transmitter in the recording mode. Adjust VR31 for Lch and VR32 for Rch so that the difference in level between 10kHz and 1 kHz is $-1\text{dB} \pm 5\text{dB}$. Repeat the above for TYPE I and confirm that the difference in level is $-X\text{dB} \pm \text{dB}$.	Difference in output between 1 kHz and 10 kHz: $-1\text{dB} \pm 5\text{dB}$	Lch: VR31 Rch: VR32

Flow of functional operation until TOC read

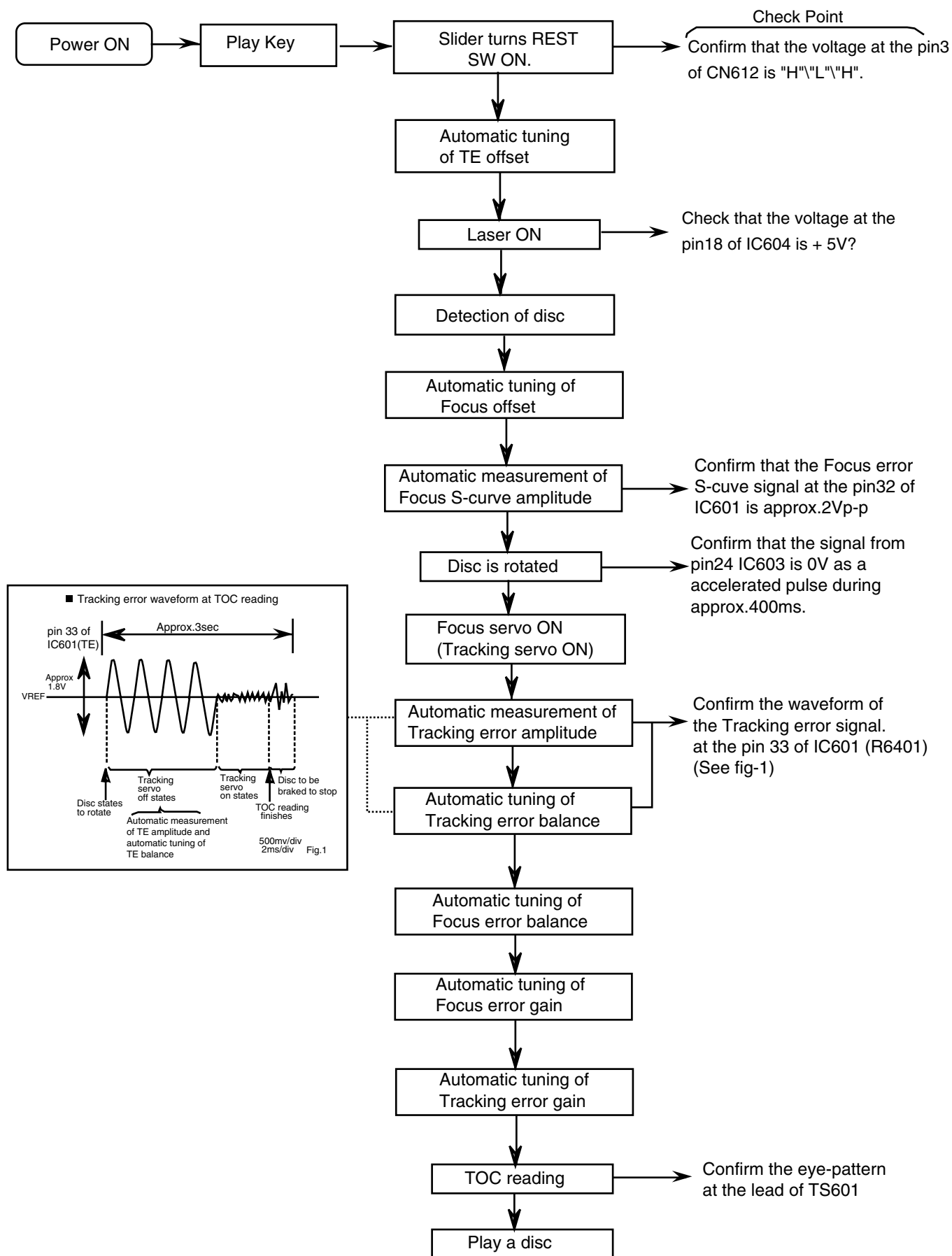

Maintenance of laser pickup

(1) Cleaning the pick up lens

Before you replace the pick up, please try to clean the lens with a alcohol soaked cotton swab.

(2) Life of the laser diode

When the life of the laser diode has expired, the following symptoms will appear.

1. The level of RF output (EFM output : amplitude of eye pattern) will below.

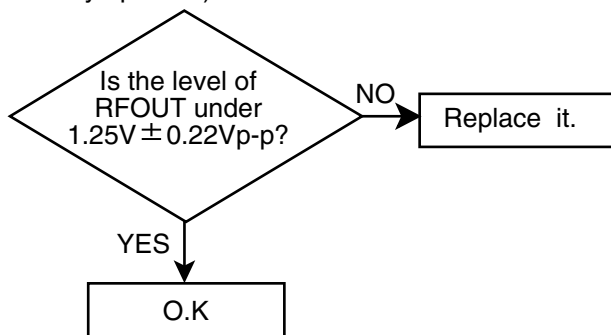

Replacement of laser pickup

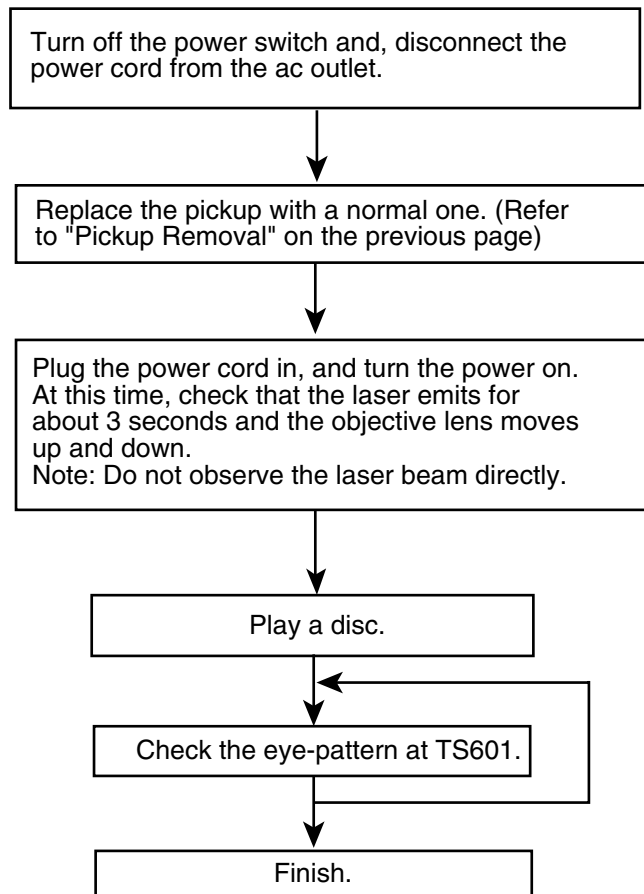

(3) Semi-fixed resistor on the APC PC board

The semi-fixed resistor on the APC printed circuit board which is attached to the pickup is used to adjust the laser power. Since this adjustment should be performed to match the characteristics of the whole optical block, do not touch the semi-fixed resistor.

If the laser power is lower than the specified value, the laser diode is almost worn out, and the laser pickup should be replaced.

If the semi-fixed resistor is adjusted while the pickup is functioning normally, the laser pickup may be damaged due to excessive current.

Description of major ICs

■ LA4905 (IC101) : Power amp IC

1. Terminal layout

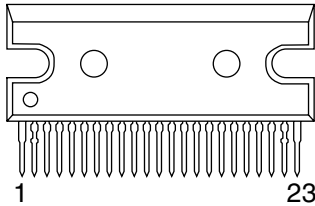

2. Block diagram

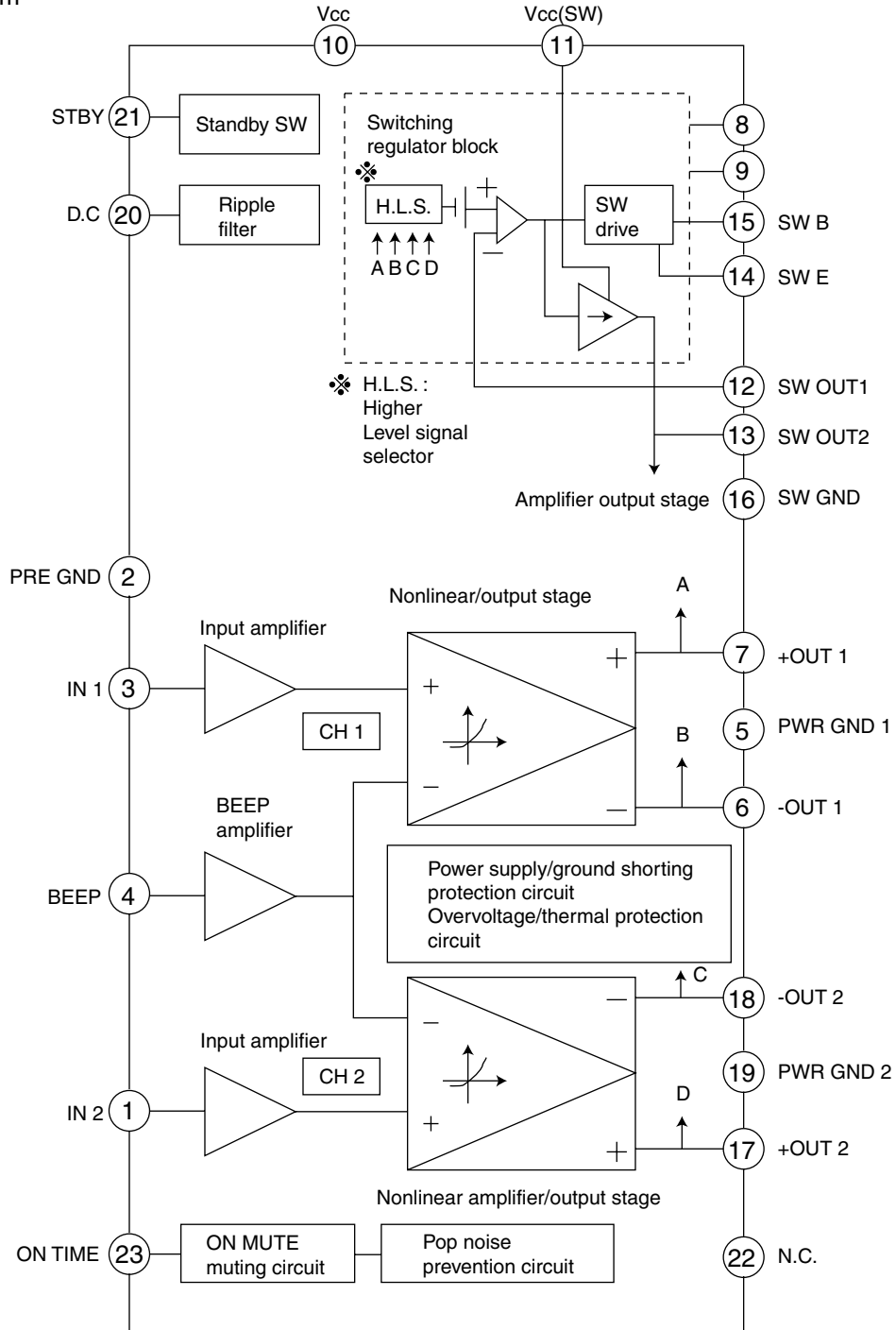

■ **BA15218F-XE (IC201, IC701) : Dual operation amplifier**

1. Terminal layout

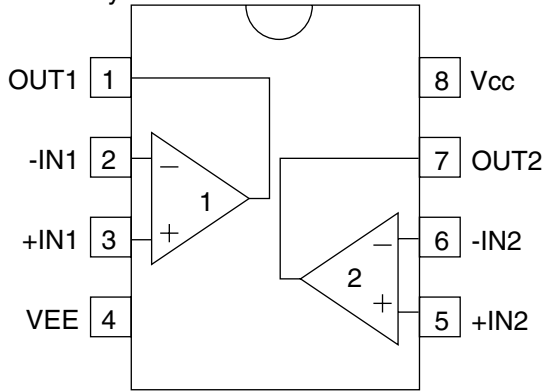

2. Block diagram

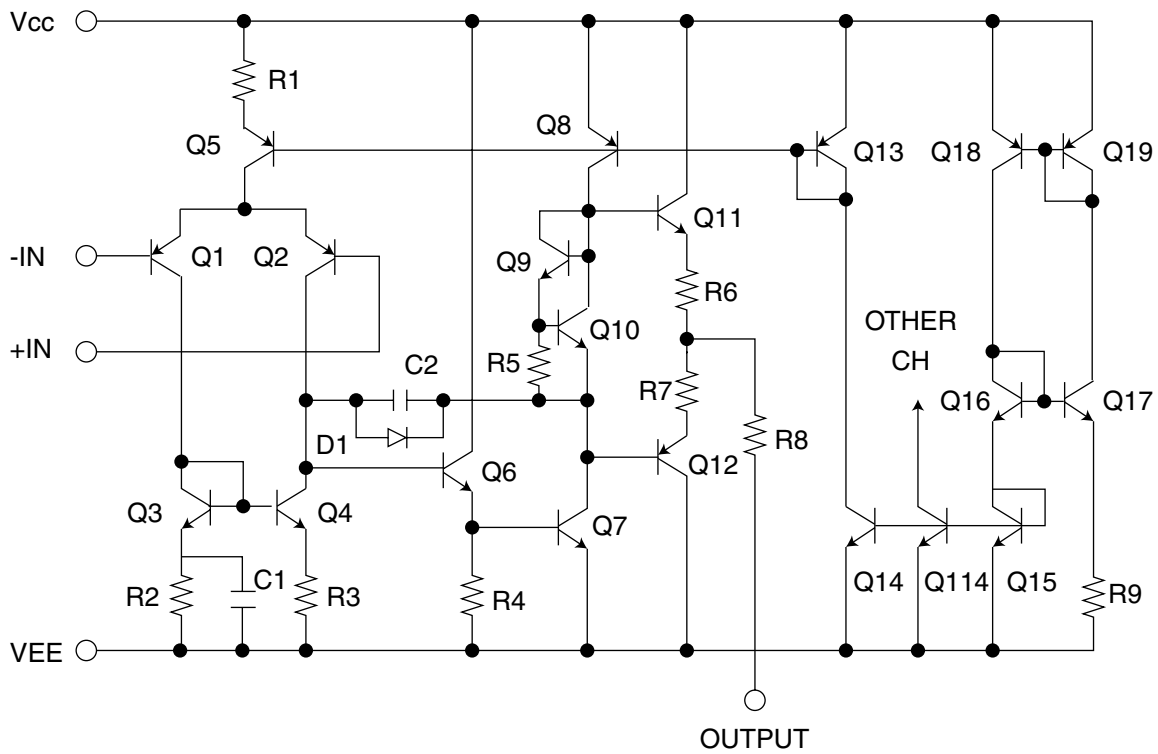

■ **GP1U281X (IC801, IC802) : Receiver for remote controller**

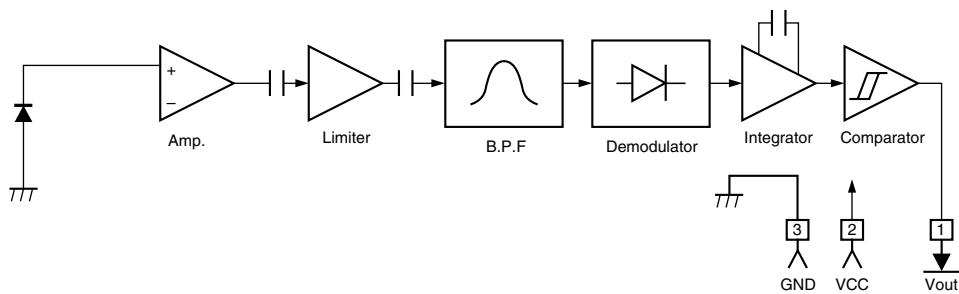

KIA78R06PI(IC381) US 6V

1. Terminal layout

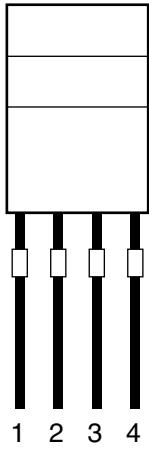

2. Block diagram

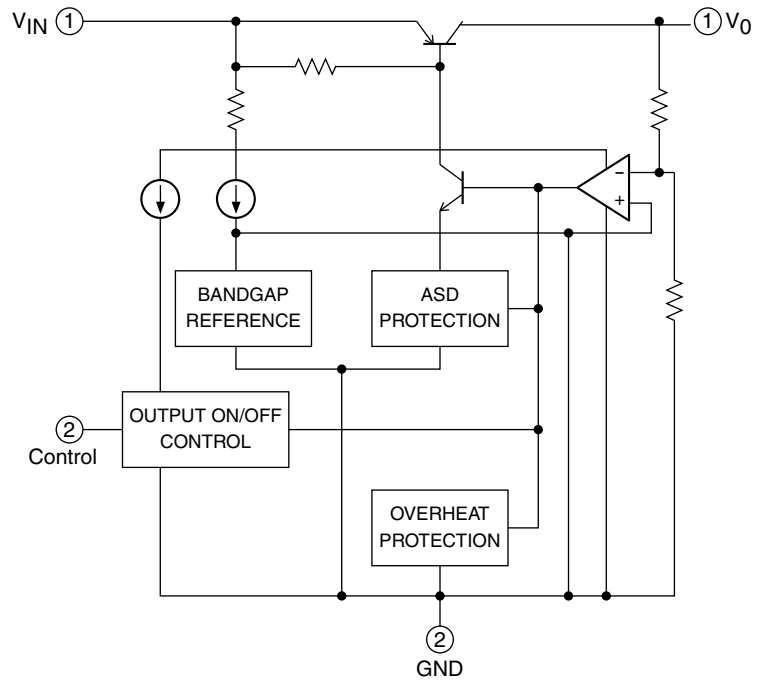

KIA78R08PI(IC301) SW 8V REGULATOR

1. Terminal layout

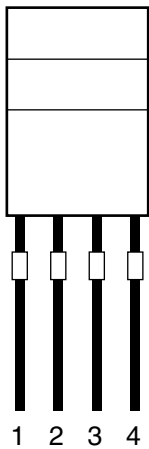

2. Block diagram

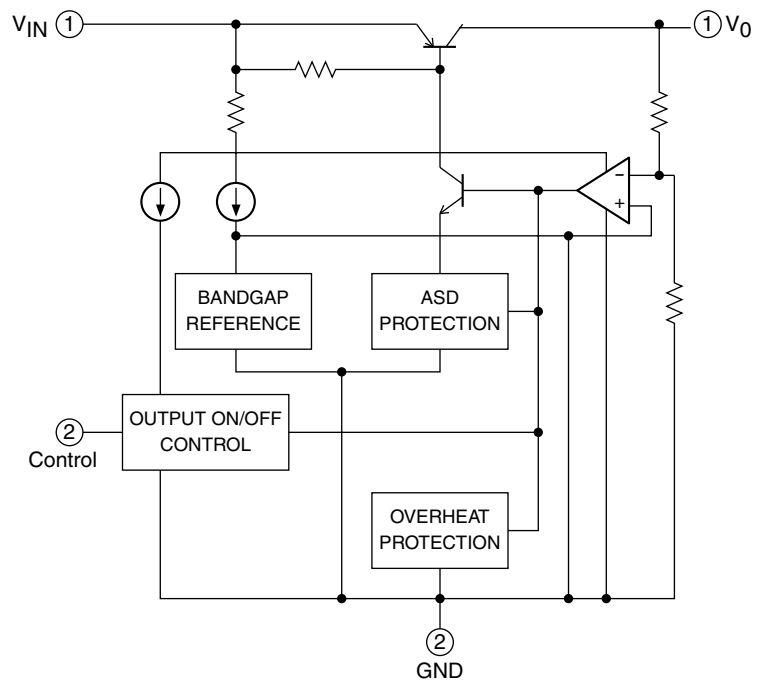

■ LC72136N (IC2) : PLL frequency synthesizer

1. Terminal layout

XT	1	22	XT
FM/AM	2	21	GND
CE	3	20	LPFOUT
DI	4	19	LPFIN
CLOCK	5	18	PD
DO	6	17	VCC
FM/ST/VCO	7	16	FMIN
AM/FM	8	15	AMIN
	9	14	
SDIN	10	13	IFCONT
	11	12	IFIN

2. Block diagram

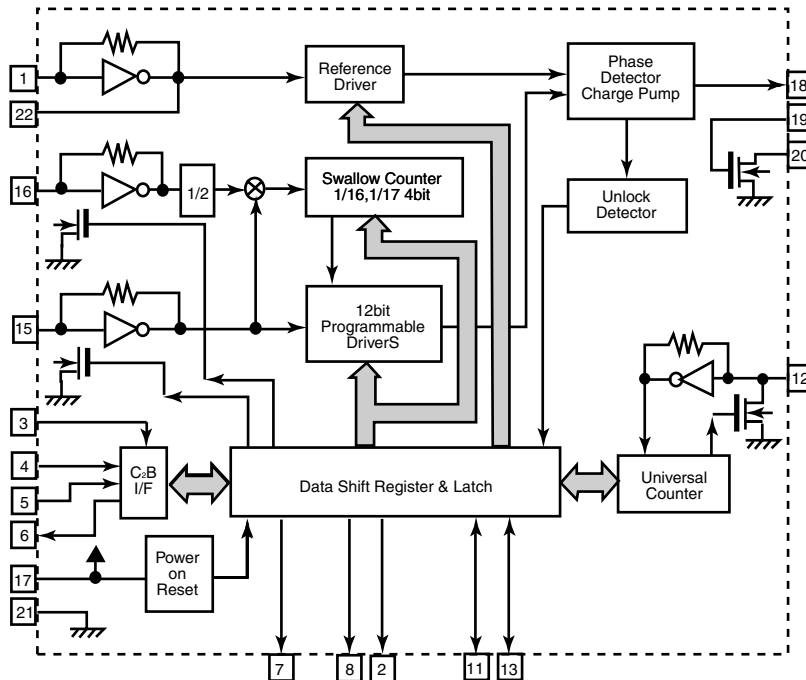

3. Pin function

Pin No.	Symbol	I/O	Function	Pin No.	Symbol	I/O	Function
1	XT	I	X'tal oscillator connect (75kHz)	12	IFIN	I	IF counter signal input
2	FM/AM	O	LOW:FM mode	13	IFCONT	O	IF signal output
3	CE	I	When data output/input for 4pin(input) and 6pin(output): H	14		-	Not use
4	DI	I	Input for receive the serial data from controller	15	AMIN	I	AM Local OSC signal output
5	CLOCK	I	Sync signal input use	16	FMIN	I	FM Local OSC signal input
6	DO	O	Data output for Controller Output port	17	VCC	-	Power supply(VDD=4.5-5.5V) When power ON:Reset circuit move
7	FM/ST/VCO	O	"Low": MW mode	18	PD	O	PLL charge pump output(H: Local OSC frequency Height than Reference frequency. L: Low Agreement: Height impedance)
8	AM/FM	O	Open state after the power on reset	19	LPFIN	I	Input for active lowpassfilter of PLL
9	LW	I/O	Input/output port	20	LPFOUT	O	Output for active lowpassfilter of PLL
10	MW	I/O	Input/output port	21	GND	-	Connected to GND
11	SDIN	I/O	Data input/output	22	XT	I	X'tal oscillator(75KHz)

■ LC75342 (IC501) : E. volume

1. Terminal layout

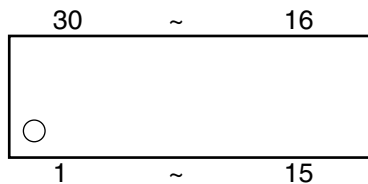

2. Block diagram

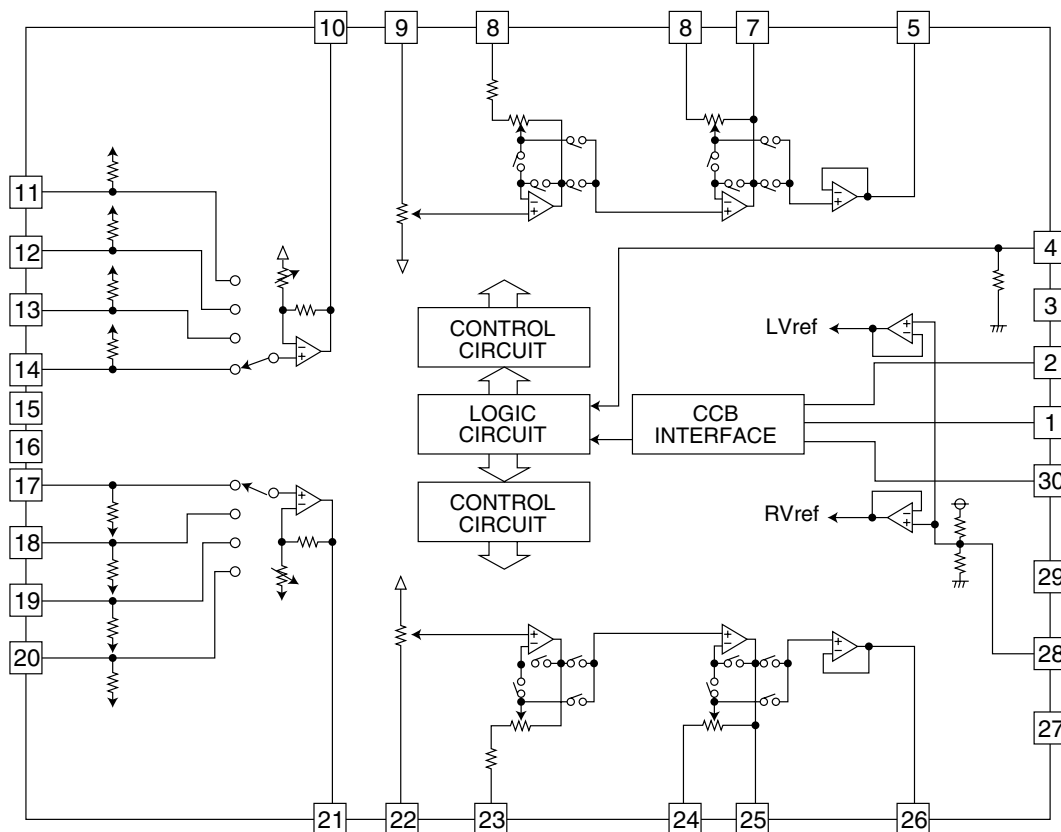

3. Pin function

Pin No.	Symbol	Function	Pin No.	Symbol	Function
1	DI	Serial data and clock input for IC control	17	R1	Input signal connections
2	CE	Chip enable	18	R2	Input signal connections
3	VSS	GND	19	R3	Input signal connections
4	TEST	Electric volume connection for test	20	R4	Input signal connections
5	LOUT	Volume control and equalizer input	21	RSELO	Input selector output
6	LBASS2	Connection for resistor and capacitor that from the bass band filter	22	RIN	Volume control and equalizer input
7	LBASS1	Connection for resistor and capacitor that from the bass band filter	23	RTRE	Connection for capacitor that from the treble band filter
8	LTRE	Connection for capacitor that from the treble band filter	24	RBASS1	Connection for resistor and capacitor that from the bass band filter
9	LIN	Volume control and equalizer input	25	RBASS2	Connection for resistor and capacitor that from the bass band filter
10	LSELO	Input selector output	26	ROUT	Volume control and equalizer input
11	L4	Input signal connections	27	NC	Not used
12	L3	Input signal connections	28	Vref	Connection to the 0.5X VDD voltage generator circuit used as the analog signal ground
13	L2	Input signal connections	29	VDD	Power supply
14	L1	Input signal connections	30	CL	Serial data and clock input for IC control
15	NC	Not used			
16	NC	Not used			

■ MN101C38CHX (IC901) : System controller

Pin No.	Symbol	I/O	Function
1~4	COM 3~0	O	FL grid control signal output
5~7	VLC 3~1	I	
8	VDD	-	Power supply +5V
9,10	OSC2,1	I/O	Oscillation terminal (8MHz)
11	VSS	-	Connect to GND
12,13	XI,XO	I/O	Sub clock (32.768kHz)
14	MMOD	-	Connect to GND
15	VREF-	I	Reference voltage (-)
16	VER	I	Version select
17	REGSAFETY	I	Regulator safety detect
18	CD5 SAFETY	I	Regulator safety detect CD5
19	CD3 SAFETY	I	Regulator safety detect CD3
20	TAPE0	I	Tape input
21	KEY1	I	Key input 1
22	GND	-	Non connect
23	MPX	I	Stereo detect
24	VREF+	I	Power supply +5V
25	SO	I	Serial data output
26	SI	I	Serial data input
27	SCK	I	Serial bus clock
28	SCMD	I	Serial data bus
29	SSTAT	I	Status bus
30	SCLK	I	Shift clock input
31	PERIDO	O	Chip enable signal output
32	RST	I	Reset input
33	BEAT	I	Beat cut sw
34	SRST	I	Reset signal for CD
35	VCE	I	Chip enable for VOL. IC
36	VDATA	I	Volume data for VOL. IC
37	VCLK	O	Volume clock for VOL. IC
38	REM	I	Remocon signal input
39	BUP	I	Buck-up detect
40	PIN	O	Power key input
41	DC/BATT	I	DC/Battery select input
42	HP JACK	I	HP jack select input
43	SMUTE	O	System mute output
44	BCTL	O	Back-up power supply control output
45	POUT	O	Power on control output
46	LLED	-	Non connect
47	STBLED	O	Stand by LED control output
48	LLED	O	Back light LED control output
49	PLAY	I	Cassette play sw detection input
50	REEL	I	Cassette reel palus detection input
51	LATCH	O	Serial data latch output
52	DOOR	I	Door open / close detection input
53	READY	I	Serial data ready input
54	MIC JACK	I	Mic jack in out detection
55	A HB 1	O	Active Hyper Bass select output signal 1
56	A HB 2	O	Active Hyper Bass select output signal 2
57	PSWOFF	I	Power sw off detection
58~60		-	Non connect
61	F. CD	O	Function for CD
62	F. TU	O	Function for tuner
63	F. AUX	-	Non connect
64	PBMUTE	O	Playback mute
65~74	GND	-	Connect to GND
75~79		-	Non connect
80~100	SEG0~20	O	FL segment signal output

■ MN35530 (IC601) : Digital servo & processor

1. Terminal layout

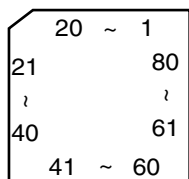

2. Pin function

Pin No.	Symbol	I/O	Function	Pin No.	Symbol	I/O	Function
1	DVD3V	-	Power supply	41	ADPVCC	I	Vcc for A/D input
2	D0	I	Data input	42	DSLFL	I/O	Loop filter pin for DSL
3	D1	I	Data input	43	DRF	I	Bias pin for DSL input
4	NWE	I/O	Write enable	44	PLLF	I/O	Loop filter pin for DSL
5	NRAS	I/O	Low address strove	45	VCOF	I	Vcc OFF input
6	D2	I	Data input	46	AVDD2	-	Power supply
7	D3	I	Data input	47	AVSS2	-	Connect to GND
8	NCAS0	I/O	Column address strove 0	48	OUTL	O	Lch audio output
9	NCAS1	I/O	Column address strove 1	49	AVSS2	-	Connect to GND
10	A8	O	Adress output	50	OUTR	O	Rch audio output
11	A7	O	Adress output	51	AVDD1	-	Power supply
12	A6	O	Adress output	52	FSEL	I	FS selection input
13	A5	O	Adress output	53	TMOD1	-	Connect to GND
14	A4	O	Adress output	54	TMOD2	-	Connect to GND
15	A9	O	Adress output	55	FLAG	O	Flag output signal
16	A0	O	Adress output	56	CVS	-	Non connect
17	A1	O	Adress output	57	EXT0	-	NC
18	A2	O	Adress output	58	EXT1	-	NC
19	A3	O	Adress output	59	EXT2	-	NC
20	DVSS2	-	Connect to GND	60	TX	O	Digital audio interface output
21	DVDD2	-	Power supply	61	MCLK	I	Micon command clock signal input
22	SPOUT	O	Spindle control output	62	MDATA	I	Micon command data input
23	TRVF	O	Traverse control output (F)	63	MLD	I	Micon command load signal input
24	TRVR	O	Traverse control output (R)	64	BLKCK	O	Sub-code block clock signal output
25	TRF	O	Tracking control output (F)	65	SQCK	O	Outside clock for sub-code Q resistor input
26	TRR	O	Tracking control output (R)	66	SUBQ	O	Sub-code Q-code output
27	FOF	O	Focus control output (F)	67	DMUTE	O	Digital mute
28	FOR	O	Focus control output (R)	68	STAT	I	Stetus signal input
29	FBAL	O	Focus balance adjust output	69	NRST	I	Reset input
30	TBAL	O	Trarcking balance adjust output	70	PC	I	Power control input
31	CSEL	I	Chip select input	71	PMCK	-	Non connect
32	FE	I	Focus error signal input (Analog input)	72	SMCK	I	Serial Master clock input
33	TE	I	Tracking error signal input (Analog input)	73	SUBC	-	Non connect
34	RF ENV	I	RF envelope signal input (Analog input)	74	SUCK	I	Clock input for sub code/serial output
35	OFT	I	Off track signal input (H:off track)	75	NCLDCK	-	NC
36	NRFDET	I	RF signal input	76	NTEST	-	NC
37	BDD	I	BDO input pin (L:detect)	77	X1	I	Input of 33.8688MHz x'tal oscillation circuit
38	LDON	I	Laser ON signal output (H:on)	78	X2	O	Out of x'tal oscillation circuit
39	ARF	I	RF signal input	79	DVDD1	-	Power supply
40	IREF	I	Reference current input	80	DVSS1	-	Connect to GND

■ MN101C30AHY (IC602) : CD micon

1. Terminal layout

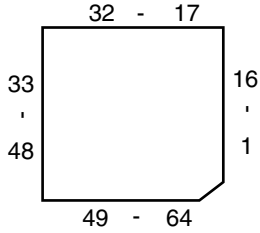

2. Pin function

Pin No.	Symbol	I/O	Function	Pin No.	Symbol	I/O	Function
1	PA3	-	Connect to GND	33	DOOR	I	Door open/close sw detection input
2	PA4	-	Connect to GND	34	O MUTE	O	Muting output
3	PA5	-	Connect to GND	35	DMUTE	O	Digital mute output
4	PA6	-	Connect to GND	36	PDOWN	I	Power off detect input
5	PA7	-	Connect to GND	37	AMUTE	-	Connect to GND
6	VREF+	-	Reference Voltage	38	P61	-	Connect to GND
7	VDD	-	Power supply	39	P62	-	Connect to GND
8	OSC2	O	X'tal OSC output terminal	40	P63	-	Connect to GND
9	OSC1	I	X'tal OSC input terminal	41	P64	-	Connect to GND
10	VSS	-	Connect to GND	42	P65	-	Connect to GND
11	X1	I	Connect to GND	43	P66	-	Connect to GND
12	X0	O	Non connect	44	P67	-	Connect to GND
13	MMOD	I	Connect to GND	45	P70	-	Connect to GND
14	SBOO	-	NC	46	P71	-	Connect to GND
15	SUBQ	I	Sub-code Q-code output	47	P72	-	Connect to GND
16	SQCK	O	Outside clock for sub-code Q resitor input	48	P73	-	Connect to GND
17	SSTAT	O	Status signal output	49	P74	-	Connect to GND
18	SCMD	I/O	Sireal data	50	P75	-	Connect to GND
19	SCLK	I	Shift clock input	51	P76	-	Connect to GND
20	SREADY	O	Start signal output	52	P77	-	Connect to GND
21	RST	I	Reset signal input	53	P87	-	Connect to GND
22	M-DATA	I	Micon command data signal input	54	P86	-	Connect to GND
23	MLD	I	Micon command load signal input	55	P85	-	Connect to GND
24	MCLK	I	Micon command clock signal input	56	P84	-	Connect to GND
25	STAT	O	Status signal output	57	P83	-	Connect to GND
26	XRST	O	Reset output	58	P82	-	Connect to GND
27	BLKCK	I	Feed Kick control output	59	P81	-	Connect to GND
28	P21	-	Eanable signal	60	ESPCHG	-	Connect to GND
29	P22	-	Connect to GND	61	VREF-	-	Connect to GND
30	P23	-	Connect to GND	62	KEY0	-	Connect to GND
31	P24	-	Connect to GND	63	KEY1	-	Connect to GND
32	REST	I	Rest sw input	64	PA2	-	Connect to GND

■ AN4801SB-W (IC603) : BTL DRIVER

1. Terminal layout

SPIN	1	28	FIN2
PC2	2	27	FIN1
TRVIN	3	26	TRIN
PC1	4	25	FOIN
RESET	5	24	VREF
NC	6	23	SVCC
NC	7	22	NC
PGND1	8	21	NC
PVCC1	9	20	STBY
TRV-	10	19	PGND2
TRV+	11	18	PVCC2
SP+	12	17	F+
SP-	13	16	F-
T-	14	15	T+

2. Block diagram

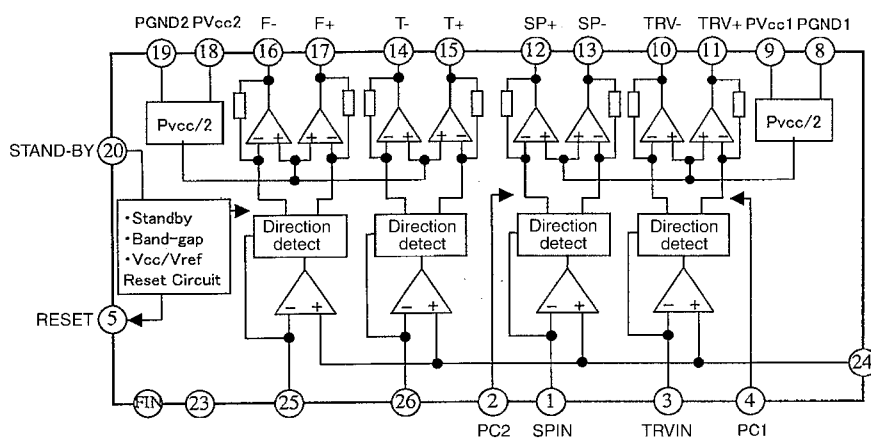

3. Pin function

Pin No.	Symbol	I/O	Function	Pin No.	Symbol	I/O	Function
1	SPIN	I	Spindle servo control input	15	T+	O	Tracking servo signal output(+)
2	PC2	I	Power control	16	F-	O	Focus servo signal output(-)
3	TRVIN	I	Traverse signal input	17	F+	O	Focus servo signal output(+)
4	PC1	I	Power control	18	PVCC2	-	Power supply
5	RESET	I	Reset signal input	19	PGND2	-	Connect to GND
6	NC	-	Non connect	20	STBY	I	Stand-by input
7	NC	-	Non connect	21	NC	-	Non connect
8	PGND1	-	Connect to GND	22	NC	-	Non connect
9	PVCC1	-	Power supply	23	SVCC	I	Reference voltage input
10	TRV-	-	Traverse drive output(-)	24	VREF	I	Voltage reference input
11	TRV+	O	Traverse drive output(+)	25	FOIN	I	Focus coil driver
12	SP+	O	Spindle servo drive output(+)	26	TRIN	I	Tracking coil driver input
13	SP-	O	Spindle servo drive output(-)	27	FIN1	-	GND
14	T-	O	Tracking servo signal output(-)	28	FIN2	-	GND

■ AN8838SB(IC604) : RF & Servo AMP

1. Terminal layout

VCC	1	28	PDF
POA	2	27	PDE
POC	3	26	VREF
POB	4	25	TEOUT
POD	5	24	TEN
RFFB	6	23	TBAL
RF	7	22	FBAL
RF IN	8	21	FEN
LPD	9	20	FEOUT
LD	10	19	ENV
CSBRT	11	18	LDON
CEA	12	17	OFTR
BDO	13	16	PDOWN
GND	14	15	RFDET

2. Block diagram

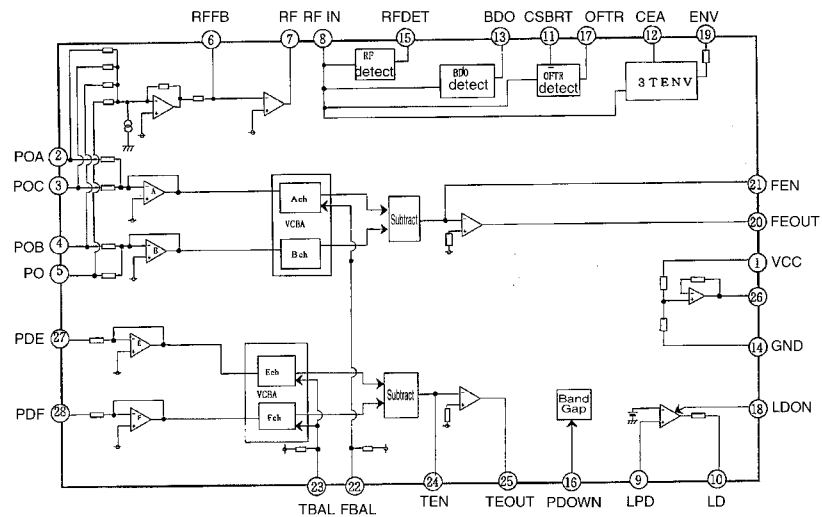

3. Pin function

Pin No.	Symbol	I/O	Descriptions
1	VCC	-	Power supply
2	POA	I	Focus signal input A
3	POC	I	Focus signal input C
4	POB	I	Focus signal input B
5	PO	I	Focus signal input D
6	RFFB	I	RFamp input
7	RF	O	RFamp output
8	RF IN	I	RF input
9	LPD	I	APC amp input terminal
10	LD	O	APC amp output terminal
11	CSBRT	I	OFF Track External terminal
12	CEA	I/O	A capacitor is connected to this terminal detect the envelope of RF signal
13	BDO	O	BDO output
14	GND	-	Connect to GND
15	RFDET	I	RF detect signal input
16	PDOWN	I	Power down input
17	OFTR	O	OFF Track output
18	LDON	I	APC ON/OFF control terminal
19	ENV	O	Envelope output
20	FEOUT	O	Output pin of focus error
21	FEN	I	Focus error amp output
22	FBAL	I	Focus balance control
23	TBAL	I	Tracking balance control
24	TEN	O	Tracking error output
25	TEOUT	O	Tracking error signal output
26	VREF	O	Reference voltage output
27	PDE	I	I-V amp input
28	PDF	I	I-V amp input

■ M11L1644SA-50T (IC605) : D RAM

1. Terminal layout

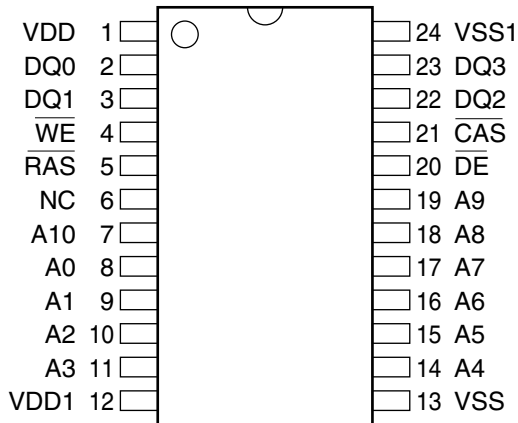

2. Pin Function

Symbol	Function
A0-A10	Address Input
RAS	Low Address strove
CAS	Column Address Strove
WE	Write enable Input
DE	Output Enable Input
DQ0-DQ3	Data in/out
VCC, VCC1	Power Supply (+3.3V)
VSS, VSS1	Power Supply (0V)
NC	Non Connect

3. Block Diagram

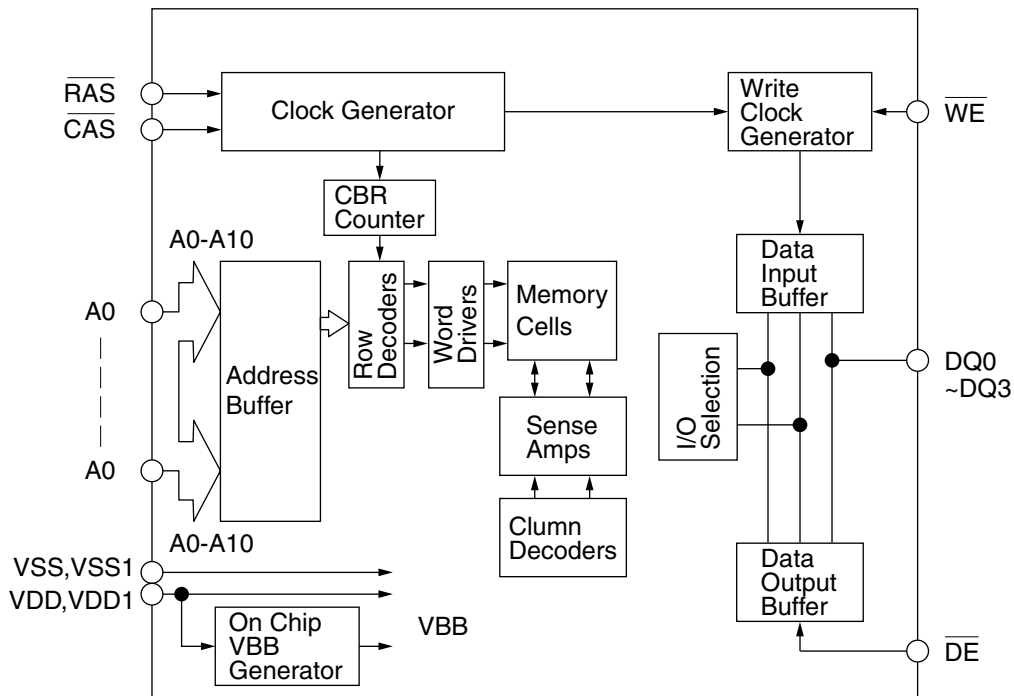

■ TA2104AN(IC1) : RadioTuner

1. Terminal layout & Block diagram

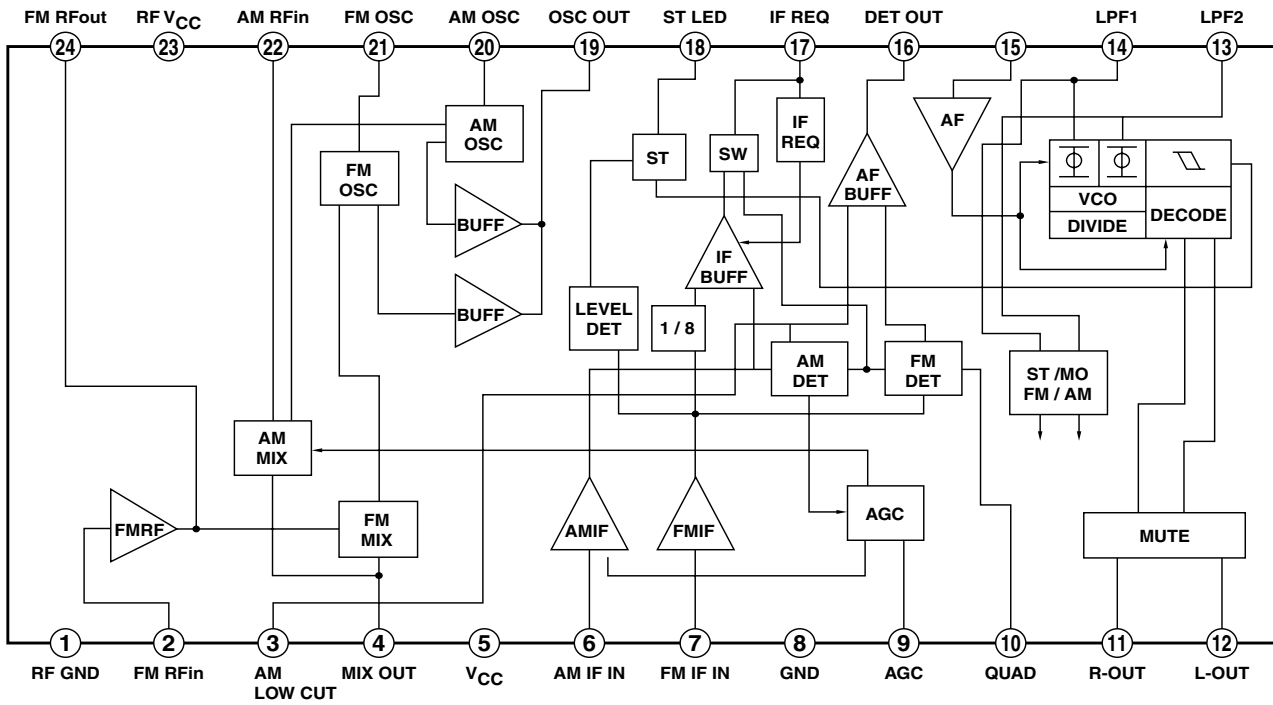



VICTOR COMPANY OF JAPAN, LIMITED
AUDIO & COMMUNICATION BUSINESS DIVISION
PERSONAL & MOBILE NETWORK BUSINESS UNIT. 10-1,1Chome,Ohwatari-machi,Maebashi-city,371-8543,Japan